

XIO3W

User Manual

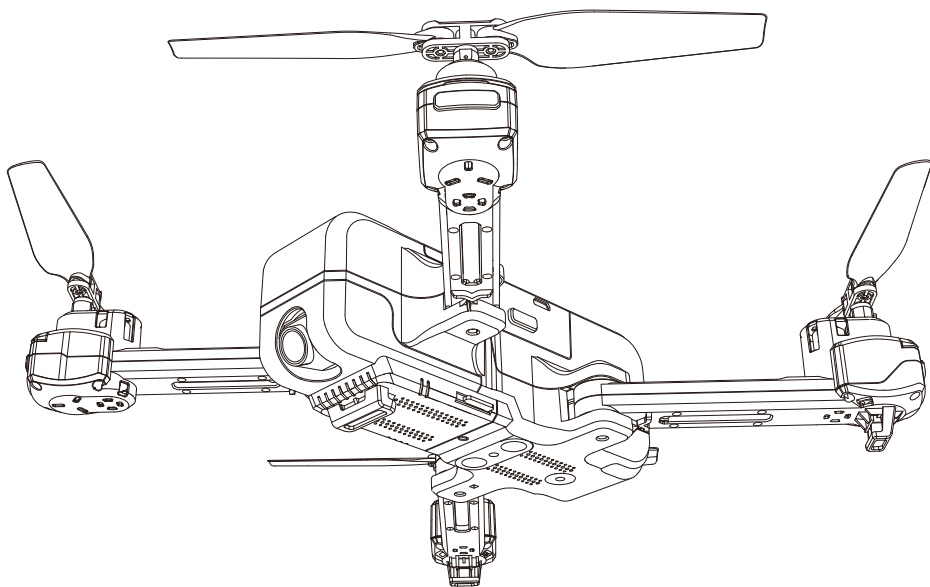

Contents

Product Features

Introduction	1
Get to know your X103W	1
Get to know the X103W remote controller	2
The X103W and remote parts identifier	3

The X103W

Flight modes	5
Drone status indicator lights	6
Return to Home (RTH) operation	7
The X103W power witch	8
Intelligent battery	8
Attaching and detaching the drone propellers	9

The X103W Remote Controller

Remote controller functions and status	10
Remote functions and setup	11
Remote controller joystick modes	13
Mobile phone installation on the remote controller	14

MJX APP for iOS and Android

FPV real-time image transmission software “MJX GPS”	15
---	----

Flying Your X103W

Safe flight requirements	17
Pre-flight checklist	18
Operating your X103W	18
Initial flight	21

Appendix

X103W product specifications	22
What’s in the box	24
Cautions and safety notes	25
Guidelines for safe flying of the X103W	25

Product Features

This section mainly introduces functions and installation guidelines of X103W and lists the components of the drone and remote controller.

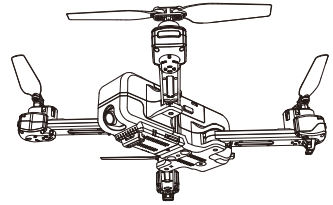

Introduction

Thank you for purchasing the MJX X103W foldable drone. This drone is equipped with an advanced Global Positioning System (GPS). The GPS communicates with satellites to enable precise positioning of the drone and hovering over a specific position. The X103W is also capable of flying in the intelligent flight modes like Point of interest, Follow me and Waypoint flight.

The drone has a single-axis gimbal for the camera that enables in flight adjustment of the camera angle from horizontal to vertical position. The camera transmits 2K videos and 2MP still pictures. The drone has a built-in micro SD card slot to record videos and still pictures in 2MP resolution.

The remote is ergonomically designed for ease of use with foldable handles that minimize the footprint of the remote when in storage or carrying. Flight information is displayed on the phone when the APP is active.

This drone has a maximum speed of 22 km/h (14 MPH) and flight time of about 14 minutes.

Get to Know Your X103W

The drone is stored in the shipping box with its arms folded. Follow the steps below to unfold the arms. Make sure the blades are free when unfolding the arms.

1. Unfold the rear arms first (the arms far from the camera);
2. Unfold the front arms next.

Note: Unfolding the arms requires a bit of force, you will feel the arm lock when it reached the fully extended position.

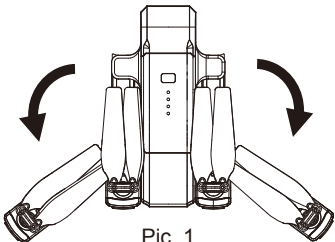

Pic. 1

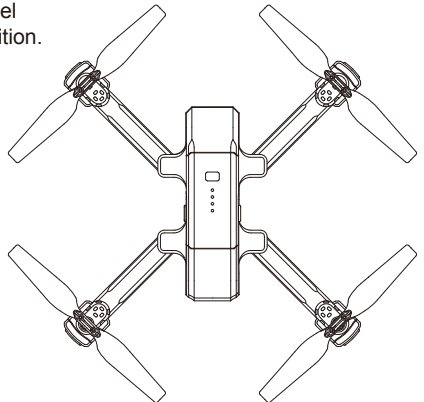

Pic. 2

Battery installation

Before first flight charge the battery to make sure it is fully charged.

ALWAYS remove the battery from the drone to charge it.

Caution: NEVER leave the battery charging unattended. Remove the battery from the charging cable when the battery is fully charged – all 4 Blue lights are on.

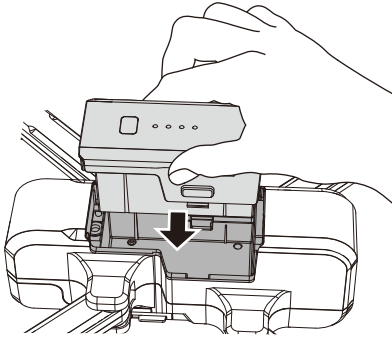

Insert the battery into the battery compartment in the top of the drone body. Make sure you insert the battery in the correct direction. Press the battery into place firmly until it locks on both sides. You will hear a click once the locking tabs are in place.



Caution: Make sure you press the battery into place firmly and hear the “click” when it is locked. Try to pull the battery out to make sure it is properly installed. A loose battery WILL cause the drone to malfunction and may cause damage to the drone or to the person flying it or others in the vicinity.

Get to Know Your X103W Remote Controller

Battery installation in the remote controller

1. Unfold the handles and open the battery compartment door (Pic. 1);
2. Install 2*AA batteries into the battery compartment and make sure they are in the correct polarity (Pic. 2);
3. Close the battery compartment door (Pic. 3).

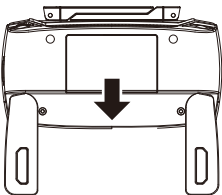

Pic. 1

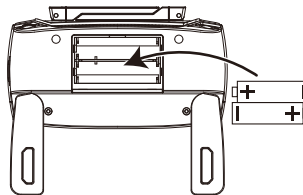

Pic. 2

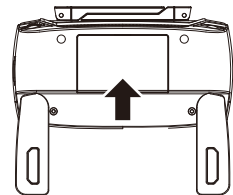

Pic. 3



- Insert batteries in the correct polarity: the transmitter requires 2*AA batteries.
- **NEVER** charge Non rechargeable batteries.
- **NEVER** mix old and new batteries.
- **NEVER** mix alkaline, standard (carbon-zinc), or rechargeable (nickel-cadmium) batteries.
- Rechargeable batteries **MUST** be removed from the drone before being charged.
- Rechargeable batteries should only be charged under adult supervision.
- Remove spent batteries from the drone and remote.
- **NEVER** short-circuit the battery terminals.

The X103W and Remote Parts Identifier

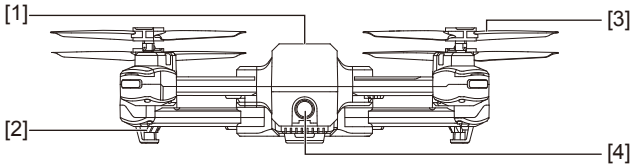

- [1] Power switch
- [2] Undercarriage
- [3] Propeller
- [4] Camera

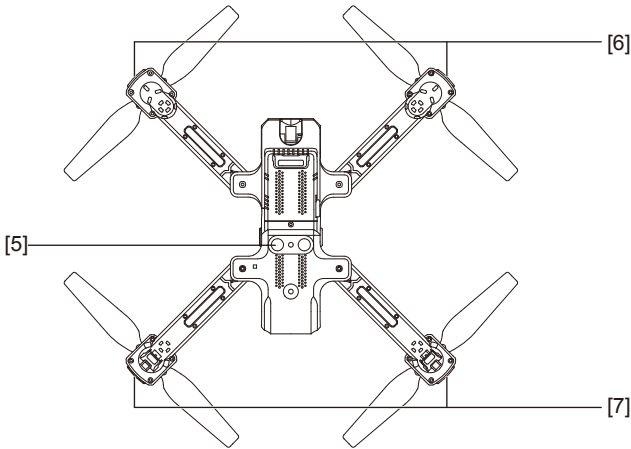

- [5] Bottom lights
- [6] Front lights
- [7] Rear lights

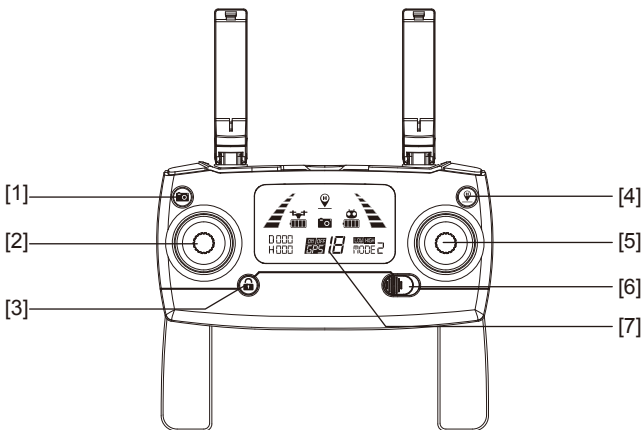

- [1] Photo/Video
- [2] Left joystick
- [3] One-key unlock
- [4] One-key RTH
- [5] Right joystick
- [6] Power switch
- [7] LCD display

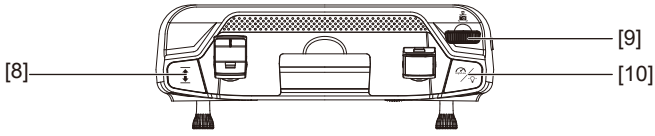

- [8] One-key takeoff/
One-key landing
- [9] Gimbal trimmer
- [10] High/Low speed
switch (short-press);
Light switch
(long-press)

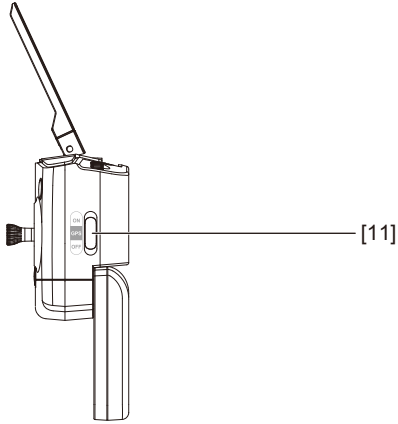

- [11] Gesture / GPS
mode switch

The X103W

This section introduces functions and features of the X103W.

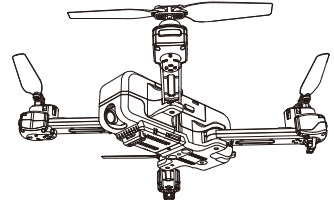

Flight Modes

Your X103W has two flights modes:

GPS mode: GPS ON

Slide the button up at the right side of the remote to "ON" (Pic.1), the drone is in GPS mode and can precisely position itself and hover in one location with the assistance of the GPS. When GPS signal is weak or the drone compass is interfered, the drone will automatically change into Gesture Mode.

Gesture mode: GPS OFF

Slide the button down to "OFF" (Pic.2), the drone is in Gesture mode. The GPS is turned off for positioning, and the drone uses only the barometer to maintain altitude. The drone will not fly with precise positioning and hovering. Gesture mode requires the pilot to have better flying skills. In Gesture mode, the drone cannot position itself or brake automatically, which increases the risk of potential flight hazards. The drone will also be more susceptible to its surroundings. Environmental factors such as wind can result in horizontal shifting, which may present hazards, especially when flying in confined spaces.

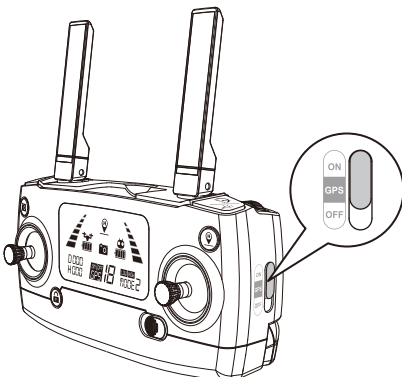

Pic.1

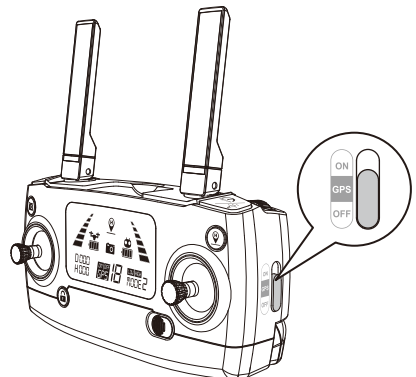

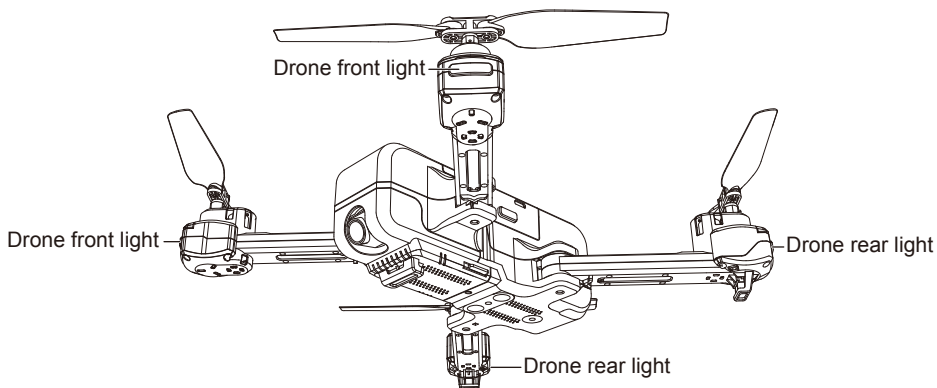

Pic.2

Drone Status Indicator Lights





Drone status indicator

No.	Indicator status	Meanings
1	Front and rear lights flash yellow rapidly.	The drone 2.4GHz communication is disconnected.
2	Front and rear lights flash red, green and yellow alternatively.	The drone is under initialization detection status.
3	Front lights are solid red, rear lights are solid green.	No GPS signal, the drone is in gesture mode.
4	Front light are solid red, rear lights are solid green.	Good GPS signal, the drone is preparing for GPS mode.
5	Front and rear lights flash green rapidly.	The drone is under gyroscope calibration status.
6	Front and rear lights flash yellow alternatively.	The drone is in compass horizontal calibration.
7	Front and rear lights flash green alternatively.	The drone is in compass vertical calibration.
8	Front lights are solid red, rear lights flash red slowly.	The drone is nearly at low voltage, only 1/4 battery capacity is left.  will be displayed on the remote controller.
9	Front lights are solid red, rear lights flash red rapidly.	The drone is at low voltage, only 1/6 battery capacity is left.  will be displayed on the remote controller.
10	Front and rear lights flash once and stop for 1.5 second.	Gyroscope error.
11	Front and rear lights flash twice and stop for 1.5 second.	Barometer error.
12	Front and rear lights flash three times and stop for 1.5 second.	Compass error.
13	Front and rear lights flash four times and stop for 1.5 second.	GPS module error.

Return to Home (RTH) Operation

The Return-to-Home(RTH) procedure brings the drone back to the last recorded Home Position. There are 3 types of RTH modes: Smart RTH, Low battery RTH and Fail safe RTH. The following sections describe each mode in detail.

	GPS	Description
Home Position		If a strong GPS signal (satellites over 7) was acquired before takeoff, the Home Position is the location from which the drone launched. The GPS signal strength is indicated by the GPS icon (). The drone rear indicator lights will blink rapidly from yellow color to green color when the home position is recorded.



- Drone can not avoid obstacles when it is flying back with the RTH function initiated.
- Drone can not return to the Home Position when the GPS signal is weak or unavailable.
- Drone will stop ascending and immediately return to the Home Position if user moves the throttle stick in the drone reaches 15meter (50 feet) altitudes or beyond during Smart RTH.
- If there is no GPS signal and the remote controller signal lost for more than 6 seconds, the drone can not Return-to-Home but descend slowly until land to the ground and lock the drone.

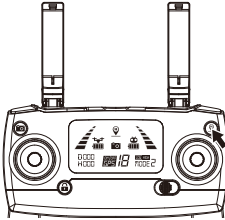

Smart RTH

Use the RTH  button on the remote controller or tap the RTH button in the “MJX GPS” APP and follow the on-screen instructions when GPS (more than 7 satellites is presented) is available to initiate Smart RTH. During the smart RTH, you can use the remote controller to guide the drone around obstacles. You can press the RTH button again to exit RTH procedure and regain control of the drone.



Low battery RTH

The low battery level Fail safe is triggered when the MJX intelligent battery is depleted to a position that may affect the safe return of the drone. Users are advised to return home or land the drone immediately when prompted.

1. When the drone rear lights flash slowly, battery icon  is shown on the remote controller or on the “MJX GPS” APP. And steady “beep beep beep... beep beep beep” sound is heard. At this moment, the drone will automatically return to the Home Position if the flying altitude is beyond 30 meters (100 feet) or the flying distance against the home position is beyond 50 meters (150 feet).
2. When the drone rear lights flash slowly, battery icon  is shown on the remote controller or on the “MJX GPS” APP. And steady “beep..beep...beep” sound is heard. At this moment, the drone will automatically return to the Home Position if the flying altitude is beyond 15 meters or the flying distance against the home position is beyond 15 meters. If the drone flying altitude is less than 15 meters or the flying distance is less than 15 meters, the drone will automatically land to the ground.



Attention: When the drone is automatically return home with Low Battery RTH function activated, you can not cancel the RTH procedure by pressing the RTH button to regain control of the drone.

Fail safe RTH

If the Home Position was successfully recorded and the compass is functioning normally, Fail safe RTH will be automatically activated if the remote controller signal is lost beyond 6 seconds. Return-to-Home can be cancelled by the pilot, allowing them to regain control when the remote controller signal connection is re-established.

The X103W Power Switch

To turn the drone ON: Once the battery is firmly installed, press the power switch for 3 seconds, the 4 Blue lights on the battery will come ON, the drone will beep and the lights on the arms will be flashing.

To turn the drone OFF: Press the power switch for 3 seconds, the drone's lights will go off and the X103W will turn off. The Blue lights on the battery will turn off.

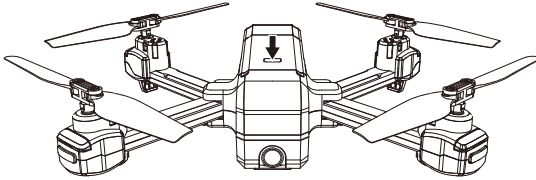

Intelligent Battery

Made by high-energy battery cells and assembled with an advance battery management system, the X103W battery is so intelligent that it is capable of managing the charging and discharging by itself. The battery capacity is 7.4V 1100mAh.

Charging the drone battery

- The drone's battery needs to be fully charged before every flight;
- Please use the MJX USB charging cord for this drone;
- Full Charging time is about 120 minutes.

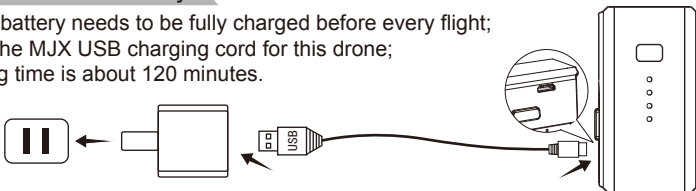

- Adult supervision is required when the drone is used by children under 14 years old.
- Only batteries of the same or equivalent type as recommended should be used.
- Insert batteries in the correct polarity.
- Rechargeable batteries **MUST** be removed from the drone before being charged.
- Rechargeable batteries should only be charged under adult supervision.
- Spent batteries should be removed from the drone.
- The supply terminals should never be short-circuited.
- The charging line to be used with the product should be regularly examined for potential hazard, such as damage to the cable, plug, enclosure of other parts. If damage is found, the product should not be used until that damaged component is properly repaired.

Attaching and Detaching the Propellers

Attaching the propellers

Install propeller A and propeller B on the corresponding motor shaft and fix the rotor propellers tightly by rotating clockwise. (A/B marks are at the bottom of the propeller)

Detaching the propellers

Rotate the screws counter-clockwise to take out the screws and remove the propellers.

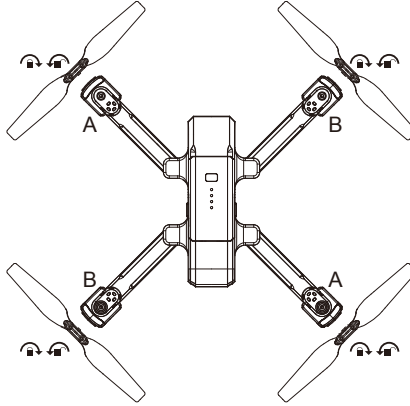

- Please make sure that the clockwise and the counter-clockwise propellers are installed on the correct motors, because the drone will not fly normally for wrong propellers installation.
- Be aware of the sharp edges of the propellers. Handle with care.
- Use only the MJX approved propellers. Do not mix propeller types.
- Stand clear of the motors and **DO NOT** touch the propellers when they are spinning.
- Check that the propellers and motors are installed correctly and firmly before every flight.
- Ensure that all propellers are in good condition before each flight. **DO NOT** use aged, chipped, or broken propellers.
- To avoid injury, **STAND CLEAR** of and **DO NOT** touch propellers or motors when they are spinning.
- **ONLY** use original MJX propellers for a better and safer flight experience.

The X103W Remote Controller

This section describes the features of the remote controller, including the instruction on controlling the X103W.

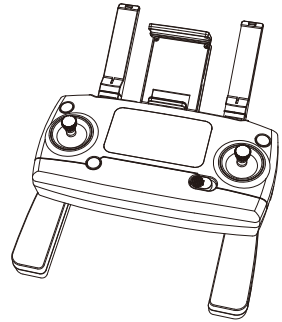

Remote Controller Functions and Status

Flight mode switch

Choose the flight mode by switching the GPS button between the ON/OFF positions.

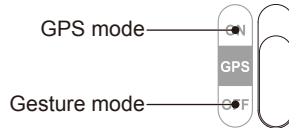
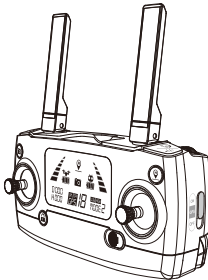

LCD Screen display

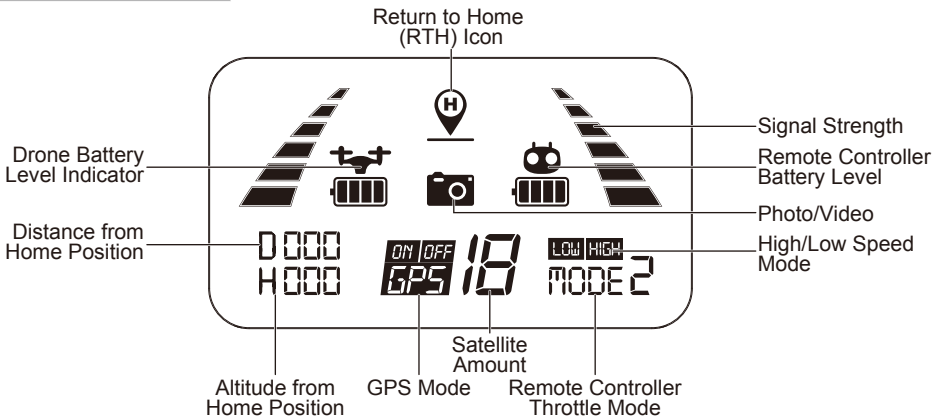

Remote Functions and Setup

No.	Remote controller status	Description
1	Signal strength indicator changes from weak to strong repeatedly.	The remote controller is under signal connection status.
2	Indicator lights flash slowly with steady "beep beep... beep beep" sound and the battery level "🔋" on LCD display is flashing.	The remote controller is under low voltage status. Please change to a fully charged battery.
3	The drone battery level "🔋" on the LCD display is as shown, with steady short "beep beep beep...beep beep beep" sound.	The drone battery is at low voltage "🔋"; the drone will return to the home position if the altitude is over 30m (100 feet) or the distance is over 50m (150 feet).
4	The drone battery level "🔋" on LCD display is as shown, with steady long beep sound.	The drone battery is at low voltage "🔋"; the drone will return when the altitude is over 15m or the distance is over 15m; if either the flying altitude or flying distance is less than 15m, the drone will land in it's position.
5	Signal strength on LCD display is less than two bars or no displaying, with steady long beep sound.	<ol style="list-style-type: none"> 1. The distance between drone and remote controller is too far causing a weak signal. 2. The battery in the drone is removed after the drone connects to the remote controller.

Gimbal trimmer

The camera angle can be adjusted from horizontal to vertical by adjusting the gimbal trimmer. This feature gives a better aerial experience. When the trimmer knob is turned upward towards the "A", the camera will tilt upward to the direction of the A; when the trimmer is turned downward towards the "B", the camera will tilt downward to the direction of the B.

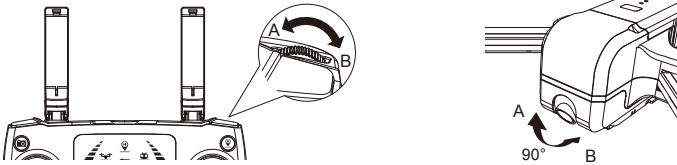

The camera angle can be adjusted 90 degrees.

Photo/Video

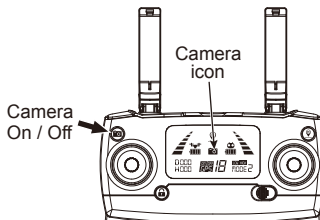

Press the camera button for a short period - the camera icon "📷" on the LCD screen will flash once, a single photo was taken; press the camera button for over 2 seconds - the video icon "📹" on the LCD screen flashes slowly, the camera is taking video. Press again for 2 seconds to exit video shooting.







Attention: When a Micro SD card is not in the drone or the micro SD card malfunctions, photos and videos can not be taken by pressing the button on the remote controller. Operating the camera can be done only from the APP installed on a phone.

One-key takeoff/One-key landing

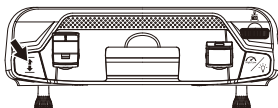
- After the X103W unlocked, short-press the “” button below, the drone will automatically take off and hover at 1.5m altitude.
- When the drone is flying, short-press the “” button below, the drone will automatically land on the ground.



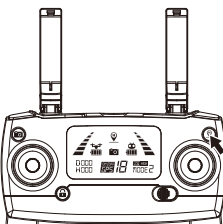

Smart RTH button

- Press the button  to start the RTH, the remote controller makes a beep sound and the drone will fly back to the recorded Home Position.
- Press the RTH button again to exit RTH procedure and regain manual control of the drone.
- For more information about RTH, please turn to Return to Home section (on page 5-6).



Low voltage warning

1. When the battery icon  is shown on the LCD screen, the drone front lights are solid on and the rear lights keep flashing slowly, the battery is nearly at low voltage condition.
2. When the battery icon  is shown on the LCD screen, the drone front lights are solid on and the rear lights keep flashing rapidly, the battery is in low voltage condition.

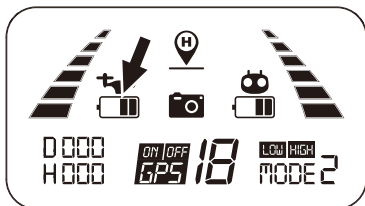

Pic. 1

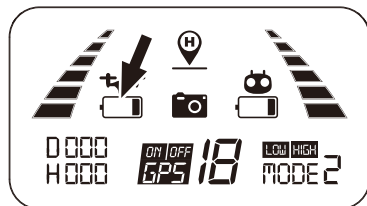

Pic. 2

Signal strength indicator

Signal strength “” shows the strength of the signal between the remote controller and the drone. More bars mean better signal.

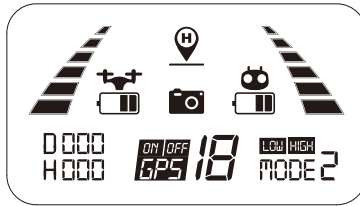

Optimal transmission zone

To obtain the best flight experience, please make sure that your X103W is flying in front of the remote controller and there are no obstacles between the drone and the remote controller.

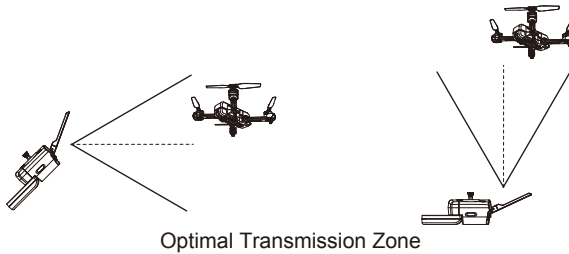

Remote Controller Joystick Modes

Remote control modes

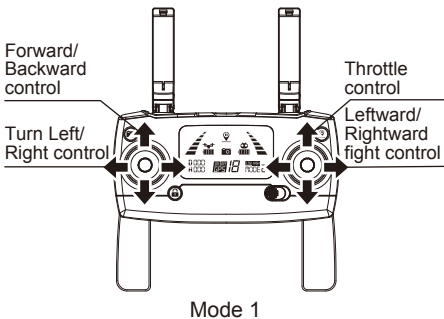

Mode 1

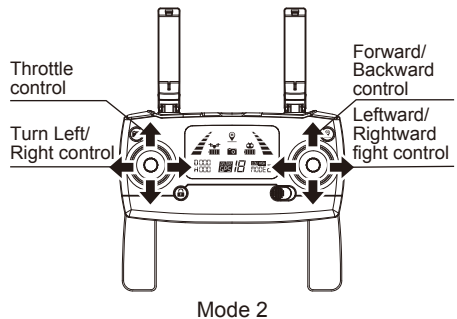



Mode 2

Mode 1: The right stick serves as the throttle.

Mode 2: The left stick serves as the throttle.

- The remote controller is set at Mode 2 by default.

Changing the remote controller mode

- Step 1. Press the red lock “” button and turn on the remote controller power, the remote controller is under signal connection status (Pic.1);
- Step 2. Press and hold the RTH button “” for 3 seconds to cycle through the remote controller modes (Pic.2). The remote controller mode will switch every time the button is pressed. The mode number is displayed on the LCD screen. The default factory setting is mode 2.

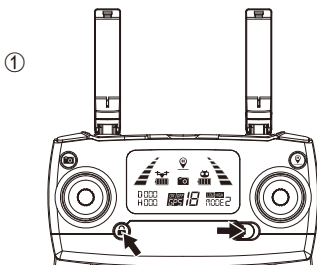

Pic. 1

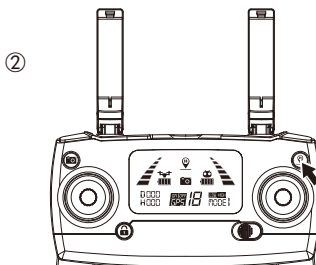

Pic. 2



Attention: To change the mode of the remote controller, please make sure that the remote controller is under signal connection status (the indicator lights keep flashing). If not, the mode can not be changed.

Mobile Phone Installation on the Remote Controller

1. Pull out the mobile phone holder upwards completely (Pic. 1);
2. Tilt the holder 30 degrees towards you and then you will hear a click sound (Pic.2);
3. Rotate and fix the support board in place (Pic. 3);
4. Place your phone in the holder and adjust the mobile phone holder upward or downward to fit the size of your mobile phone (Pic. 4).

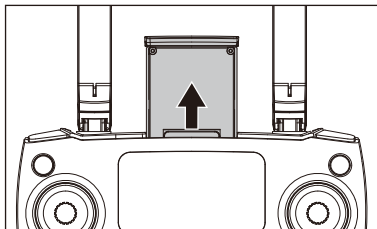

Pic. 1

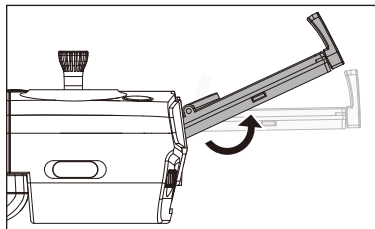

Pic. 2

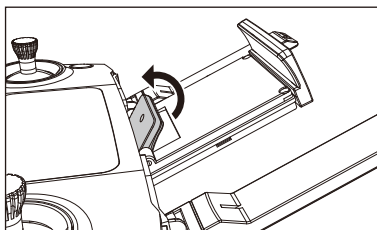

Pic. 3

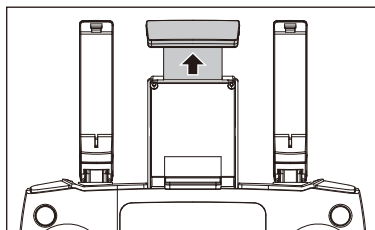

Pic. 4

MJX APP for iOS and Android

This section introduces how to download the “MJX GPS” APP and connect with mobile device.

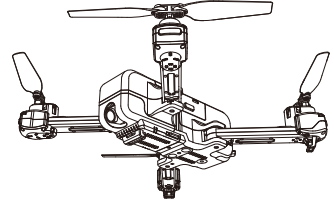

FPV Real-time Image Transmission Software “MJX GPS”

Where to download “MJX GPS” APP

1. For Apple iOS systems, please turn to Apple store, search “MJX GPS” or scan the QR code below to download the software.
2. For Android systems, please scan the “Google play” or “MJXRC.NET” QR code or search “MJX GPS” in “Google play” to download the software.



How to link the “MJX GPS” to the camera

Power on the drone, then enter phone settings option. Turn on WiFi, find drone**** on the list and connect it. When “” legend is shown, the WiFi connection is successful. Exit settings and tap “MJX GPS” APP on your mobile device, then select your drone model on the home page; click “GO” to enter into the real-time image transmission interface.

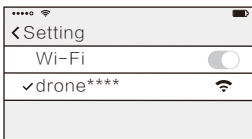

Connect WIFI



Tap “MJX GPS” App



Click “GO”

Photos and video saving feature

1. If the camera is without SD card, videos and photos will be saved on the phone using the APP.
2. If the camera is with SD card, videos and photos will be saved on the SD card.
3. Videos and photos in the SD card can be downloaded to the APP.



Attention: Please make sure that your mobile device supports 5G WIFI before linking the "MJX GPS" APP to your device.



Real time image quality and FPV distance depend on your smart phone and flight environment. To obtain the best live view, please choose a wide open area to fly in. As tested, the X103W could transmit 2K videos up to 800 meters (0.6 mile) in an environment with no interference.

Flying Your MJX X103W

This section introduces safe flight requirements and basic drone operations.

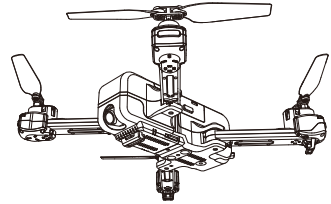

Safe Flight Requirements

1. Please don't fly the drone in bad weather conditions such as high temperature, snow, strong winds (over 15MPH), rain or fog.
2. Always choose a wide open area to fly the drone. Tall structures and large metal structures may affect the accuracy of the onboard compass and GPS system.
3. Keep away from people and private property. Never fly directly over people or animals.
4. To minimize interference, please do not fly the drone in locations near power lines, military bases, electrical substations and broadcasting towers.
5. The drone and battery performance are subject to environmental factors like temperature. Be very careful when flying the drone over 6KM (9000 feet) above sea level since the drone performance will be severely reduced.
6. Your X103W cannot use GPS within the polar regions.

Flight limits and GEO zones

Abide by all laws and regulations when flying your X103W. Flight limitations are pre-programmed into the "MJX GPS" to help users operate the drone safely and legally. Flight limitations include altitude limits, distance limits and GEO Zones.

Altitude limits, distance limits and GEO Zones function are implemented to manage flight safety when operating in GPS Mode.

No-fly zone

All Flight Limits and GEO Zones are listed on MJX official website www.mjxrc.net. The Zones are divided into different categories and include locations such as airports, flying fields where manned drone operate at low altitude, borders between countries, and sensitive location such as power plants.



The drone will be banned or restricted in the no-fly zone. MJX GPS APP will send out the corresponding warning. Please pay attention to it at all times.

Pre-flight Checklist

1. The Drone battery, remote controller and mobile device are fully charged;
2. The propellers are installed correctly;
3. The arms and propellers are fully unfolded and secured;
4. Ensure the camera lens are clean;
5. Use only MJX parts or parts certified by MJX. Unauthorized parts or parts not from MJX certified manufacturers may cause malfunction causing damage to the drone, endanger the operator and others or cause safety issues.

Operating Your X103W

Signal connection between the drone and remote controller

- Press and hold the red button “” and turn on the remote controller power switch (Pic. 1). The remote controller will beep twice, and the signal strength bars “” will be flashing; the remote controller is under signal connection status.
- Turn the drone power to On (Pic. 2). The drone will beep and the front and rear lights will be flashing. The drone will automatically link to the remote controller. Once the remote controller sends out a long beep sound and the signal strength bars on the remote controller turn from flashing to solid on and the signal icon “” is displayed on the LCD screen, it means that the signal connection is successfully completed.

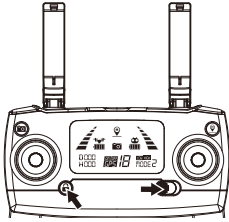

Pic.1

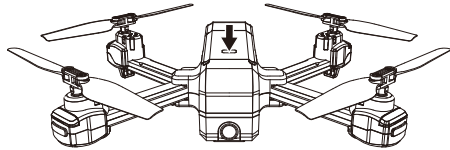

Pic.2



- Signal connection is done once for all if the remote controller is not linked to other drones.
- Set the connection one by one to avoid signal connection error if multiple drones are used in the same area.

Drone initialization detection

After signal connection, the drone enters into initialization detection procedure with front and rear lights flashing red, green and yellow alternatively. Make sure that the drone is set on a flat and still surface for the initialization detection. The drone initialization detection takes about 8 seconds. Once the remote controller sends out 2 beep sounds and the drones front and rear lights flash yellow alternatively, initialization detection is completed.

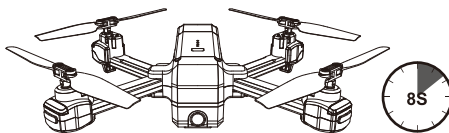

Attention: Make sure that the drone is set on a flat and still surface for the initialization detection.

Drone compass calibration

1. Compass calibration should be performed after successful drone initialization detection.
2. The drone compass calibration should be done before every flight. If the battery changed to a new one or the battery is reinstalled, the compass calibration should be repeated.

Two steps of compass calibration:

Step 1: Horizontal calibration

After successful drone initialization detection, the drones front and rear lights flash yellow alternatively. Hold the drone horizontally and turn it 360 degrees along the vertical axis 3 circles. The drone front and rear lights will change from flashing yellow alternatively to flashing green alternatively when horizontal calibration is completed.

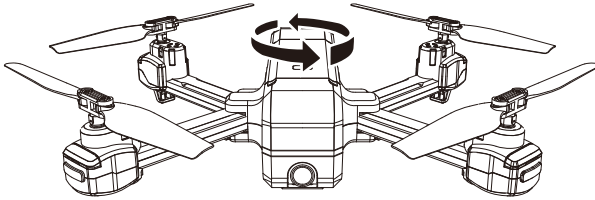

Step 2: Vertical calibration

Hold the drone with the **camera facing up**, and turn it 360 degrees along the longitudinal axis 3 circles. The front and rear lights of the drone will change from flashing to solid on, the compass calibration is completed successfully.

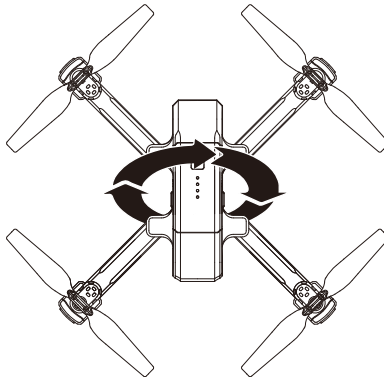

Attention: To fly in GPS mode, please choose an open space for the flight, and make sure that the satellite amount is over 7.



- Please do not calibrate the compass in strong magnetic area, such as magnetic field, parking garage or construction area with underground metal reinforcement.
- Please stay 10 feet away from magnetic materials (such as keys, cell phones, etc) when calibrating the compass.
- Please keep away from large metal objects when calibrating the compass.

Gyroscope calibration

After the drone and the remote controller are bound, set the drone on a flat surface (Pic. 1), push and hold both joystick to the lower left position (Pic. 2) to calibrate the gyro. Once the drone front lights turn from flashing to solid on, the gyro calibration completes successfully.

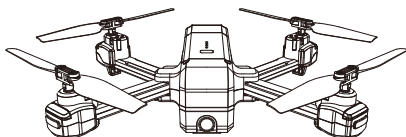

Pic. 1

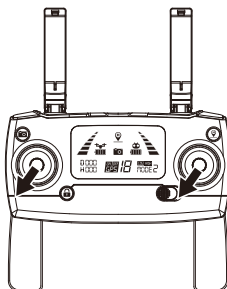



Pic. 2



- The gyroscope calibration was done at the factory. Gyroscope calibration is not needed unless the drone can not exit the drone initialization detection procedure.
- Please make sure to set the drone on a flat horizontal surface when performing calibration, failure to do this will affect the flight characteristics.



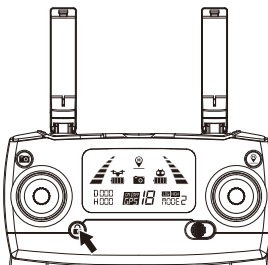

How to lock and unlock the drone

- To unlock the drone: Press the red button “”. The motors will start rotating, the drone is unlocked.
- To lock the drone: After the drone lands on the ground, press the red button “” for 3 seconds, the motors will stop rotating and the drone is locked.

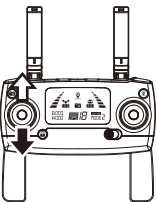
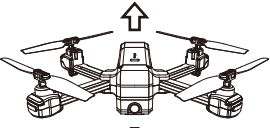
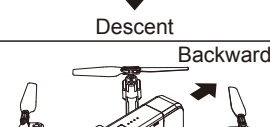
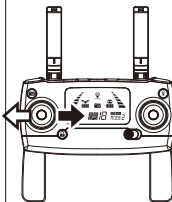
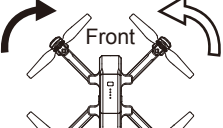
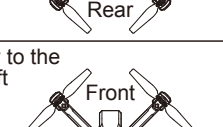
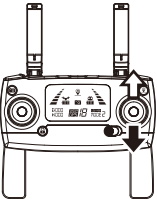
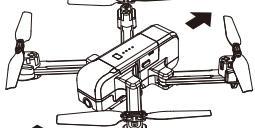

Warning: **NEVER** attempt to lock the drone by pressing the “” button when the drone is airborne !!! Or the drone **WILL** crash and be damaged.

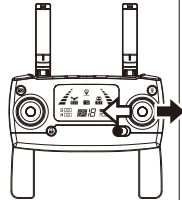
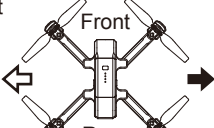
Drone operation

Remote controller	Drone	Remote controller	Drone
	<p>Ascent</p>  <p>Descent</p> 		<p>Turn Right</p>  <p>Turn Left</p> 
	<p>Backward</p>  <p>Forward</p> 		<p>Fly to the Left</p>  <p>Fly to the Right</p> 

Initial Flight

Basic flight operation steps

1. Place the drone in a wide open area with its front facing away from you.
2. Turn on the drone and remote controller.
3. Connect the remote controller with the drone and then proceed the drone initialization detection.
4. Connect your X103W with your phone and enter into the image transmission interface.
5. Unlock the drone after the drone gyro detection is completed.
6. Push the throttle joystick forward, the drone will take off; Control the drone's flight with left/right joystick.
7. Push the throttle joystick down to land the drone.
8. Push down the throttle joystick and keep it at the bottom position for 3 seconds to lock the drone.
9. Remove the battery from the drone and turn off the remote controller.

Video suggestion and tips

1. Complete the pre-flight checklist;
2. Set the camera gimbal angle to your desired position;
3. Fly the drone in good weather with little wind;
4. Perform test flights to establish flight routes and to preview scenes;
5. Push the control joystick gently to keep the drone movement smooth and stable.



Please keep flight safety guidelines in mind to prevent accidents and crashes.

For more information, please turn to Appendix.

Appendix

X103W Product Specifications

Drone	
Gross Weight (Battery and propellers included)	X103W: 246g (8.7 Oz)
Dimensions	Folded: 150*100*60mm (length*width*height) (6*4*2.4 inch) Unfolded: 345*345*60mm (length*width*height) (13.6*13.6*2.4 inch)
Diagonal	255mm (10 inch)
Max Ascent Speed	2m/s (6.56f/s)
Max Descent Speed	2m/s (6.56f/s)
Max Speed	22km/h (14 MPH)
Flight Height Limitation	80m (260 feet)
Max Flight Time	14 minutes (no wind)
Max Wind Speed Resistance	≤Level 2
Max Tilt Angle	35°
Max Angular Velocity	200°/s
Operating Temperature Range	0°C-40°C
GNSS	GPS
Hovering Accuracy Range	Vertical±0.5m (1.5 feet) Horizontal±1.5m (4.5 feet)
Operating Frequency	2.4-2.4835GHz 5.15-5.35GHz
Transmission Power (EIRP)	2.4GHz≤20dBm 5GHz≤16dBm
Gimbal	
Controllable angle	Tilt: -90° - 0°
Camera	
Image Sensor	1/3 " CMOS; Effective Pixel: 2 million
Lens	FOV: approx. 110° Aperture: f/2.4 Shooting Range: 1m to ∞
ISO Range	Photo: 100-1600 (Auto) Video: 100-1600 (Auto)
Electronic Shutter Speed	Electronic Shutter: 1/30s-1/10000s
Still Image Size	2048x1152
Still Photography Modes	Single Shot
Video Resolution	2K: 2048x1152
Color Mode	RGB Mode
Max Video Bitrate	Video 12Mbit/Transmission 2Mbit
Supported File System	FAT32
Photo Format	JPEG Format

Video Format	MP4, Compressed Format H.264
Supported SD Cards	≥Class 10 Micro SD Cards (not included)
Operating Temperature	0°C-40°C
Remote Controller	
Operating Frequency	2.4-2.4835GHz
Max Transmission Distance	800m (0.51 mile)
Operating Temperature	0°C-40°C (32-100 F)
Battery	2*AA
Transmission Power (EIRP)	2.4GHz≤20dBm
Operating Current/Voltage	200mA@3V
Intelligent Flight Battery	
Capacity	1100mAh
Voltage	7.6V
Operating Temperature	LiPo 2S
Energy	8.36Wh
Net Weight	61g
Charging Temperature Range	5°C- 40°C
Charging Current	≥1.5A (Max) 2A Adaptor
Charging Time	120 minutes
APP	
APP Name	MJX GPS
Image Transmission System	WIFI 5GHz
Real-time Image Transmission	720p@20fps
Latency	200-300ms
Required Operating System	iOS 9.0 or later Android 4.4 or later

What Is in the Box

Package includes the following parts.

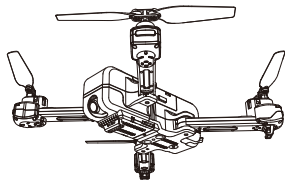

Drone *1

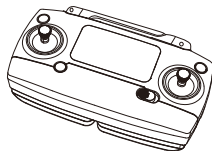

Remote Controller *1



Extra propellers set *1



USB charging Cable *1



Screwdriver *1

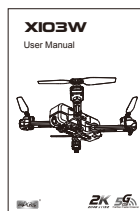

User Manual *1

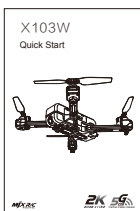

Quick Start *1

Cautions and Safety Notes

- This drone is not a toy, but a hobby grade model. It should be assembled and operated properly. Pilot must operate this drone in a safe way. Improper operation may cause injury or property damage.
- This drone is appropriate for pilots aged 14+ who are skilled with flying experience.
- Users are in fully responsible for proper operating this drone. The manufacturer distributor or dealers will bear no responsibility for damages caused by misuse.
- Keep small accessories away from kids to avoid accident.

Guidelines for Safe Flying of the X103W

Hobby grade radio control drones are considered to be the most dangerous potential products.

Users should conform to the principle of “safety comes first”. **Never** fly the drone close to airports, above crowds or in zones storing dangerous goods. **REMEMBER**, you are responsible for accidents caused by improper operation.

● **Stay away from obstacles, crowds, power lines, trees or water**

Always choose a wide open area for every flight, away from people and property. Never fly directly over people or animals. Please don't fly the drone in bad weather conditions as high temperature, snow, strong wind (\geq level 5), rain or fog. Maintain a 2m (7ft) distance from the drone when taking off or landing.

● **Keep the drone in dry environment**

The drone is composed of sophisticated electronic components and mechanical parts. To avoid damages on the mechanical and electronic components, please keep the drone in dry environment and use a clean cloth to wipe the surfaces and keep it clean.

● **Practice flying together with skilled pilot**

Beginners are suggested to practice flying together with skilled pilot's guidance. Do not fly alone.

● **Keep proper operation and safe flight guidelines in mind**

Please read carefully the user manual before flying the drone. It contains important information on product functions and operation tips. Learn how to use the accessories, safe flight always comes first. Stay informed of and abide strictly by relevant local laws and regulations. Keep away from any no-fly zones and respect other people's privacy.

● **Safe flying**

Please make sure you are in good mental shape before every flight. Fly the drone as per your flying experience. Never fly the drone under the influence of alcohol or drugs. Keep the remote controller at least 20 cm (8 inches) away from your body when flying the drone.

● **Keep a safe distance from a flying drone**

Never touch a flying drone under any circumstance. Don't approach and touch a drone on the ground if its propellers are rotating. Severe injuries may be caused by rotating propellers.

● **Keep away from heat source**

The drone is made of metal, fiber, plastic, electronic component and other material. Please keep it away from any heat source to avoid deformation. Never leave the drone in the sun, damage will be caused by sun exposure and high temperature.

● **Environmental protection requirements**

To protect our blue planet, please recycle the drone conforming to local laws and regulations.

Note:

- a) Changes or modifications not expressly approved by the party responsible for compliance could void the user's authority to operate the equipment.
- b) This equipment has been tested and found to comply with the limits for a Class B digital device, pursuant to part 15 of the FCC Rules. These limits are designed to provide reasonable protection against harmful interference in a residential installation. This equipment generates, uses and can radiate radio frequency energy and, if not installed and used in accordance with the instructions, may cause harmful interference to radio communications. However, there is no guarantee that interference will not occur in a particular installation. If this equipment does cause harmful interference to radio or television reception, which can be determined by turning the equipment off and on, the user is encouraged to try to correct the interference by one or more of the following measures:
- Reorient or relocate the receiving antenna.
 - Increase the separation between the equipment and receiver.
 - Connect the equipment into an outlet on a circuit different from that to which the receiver is connected.
 - Consult the dealer or an experienced radio/TV technician for help.



MADE IN CHINA