



CLRACINGF7 MPU V2

The Flight Controller for RACERS

Main Features

1. MCU: STM32F722RET6216MHz
2. 6-Axis MPU6000 Separated Interrupts
3. Build in Beta flight OSD
4. Up to 8S(36V) direct battery power
5. Build in Voltage monitoring resistor
6. Build in 5V/3A BEC and 3.3V/250mA for system
7. Led strip share 5V with 5V/3.0A BEC
8. 5V OR VBAT, camera and VTX POWER VIA Pit Switch
9. 6 Full UARTS: UART1, UART2, UART3, UART4, UART5, UART6
10. Buildin Camera Control pin with necessary resistor and capacitor near camera connection
11. Buzzerpads for external buzzer
12. VBAT Polarity protection
13. Build in 32MB Blackbox flash chip
14. M4 Can be selected either led strip signal or M4 signal for RPM filtering

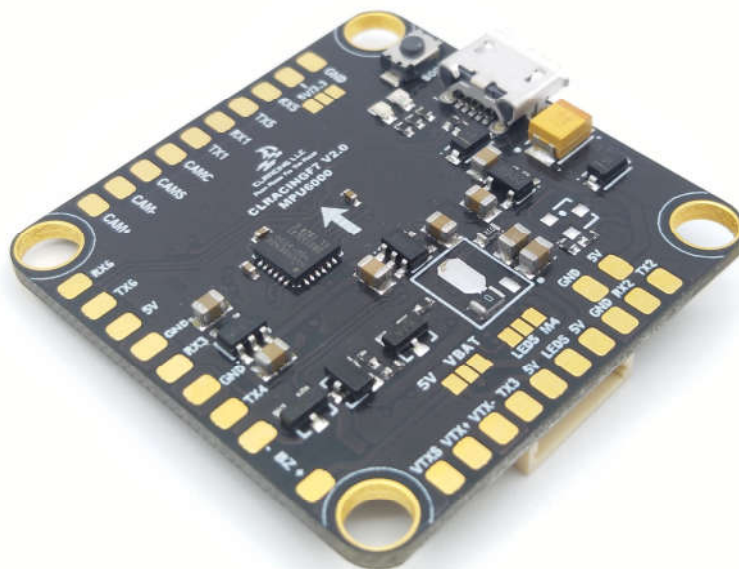

General Overview

1. FC TOP VIEW

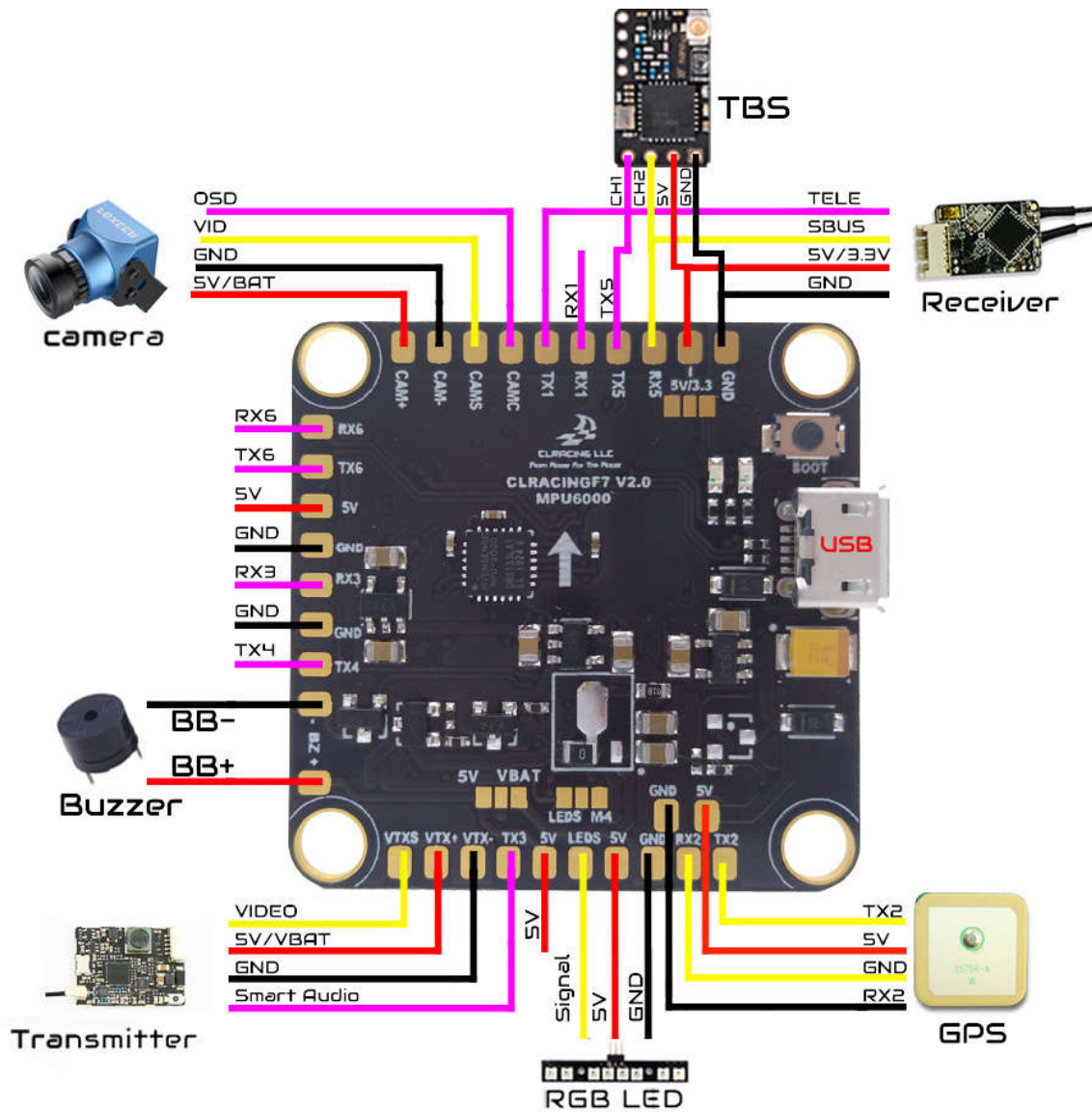

2. FC BOTTOM VIEW

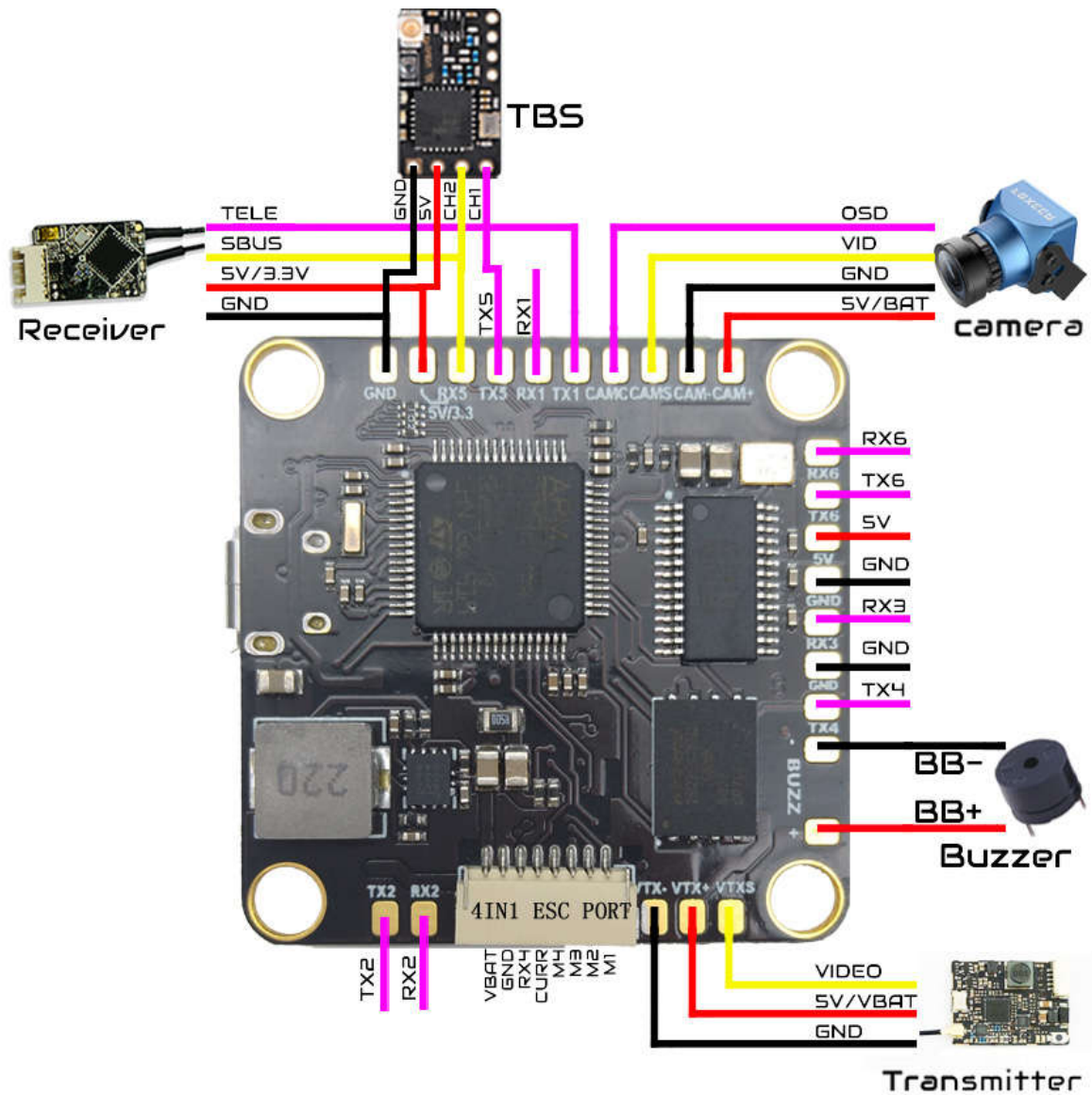

3. FC + 4in1 ESC

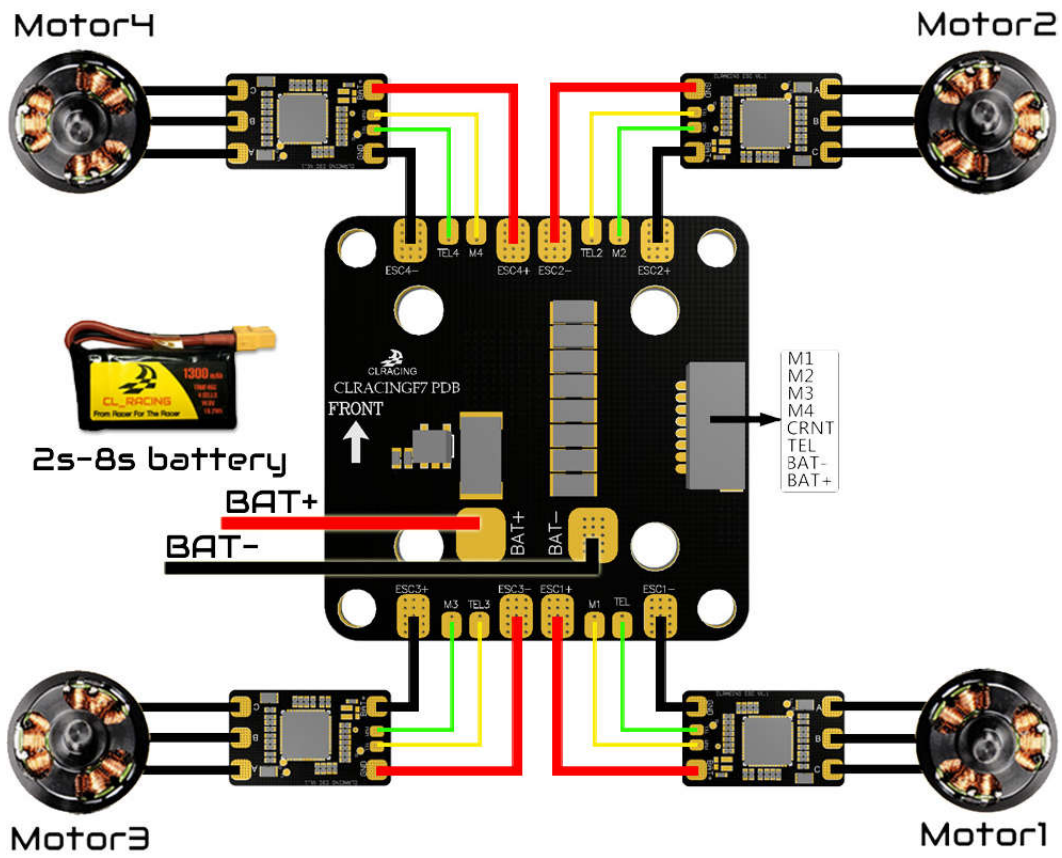
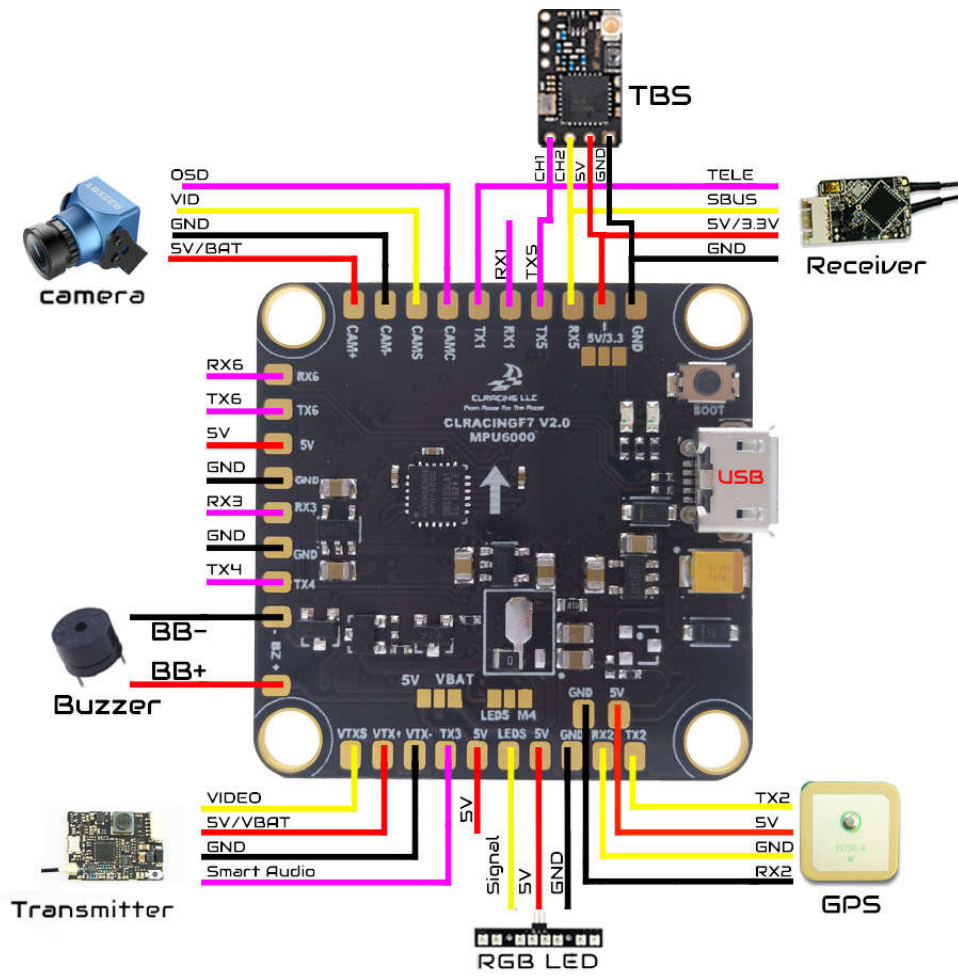

4. FC + 4in1 ESC

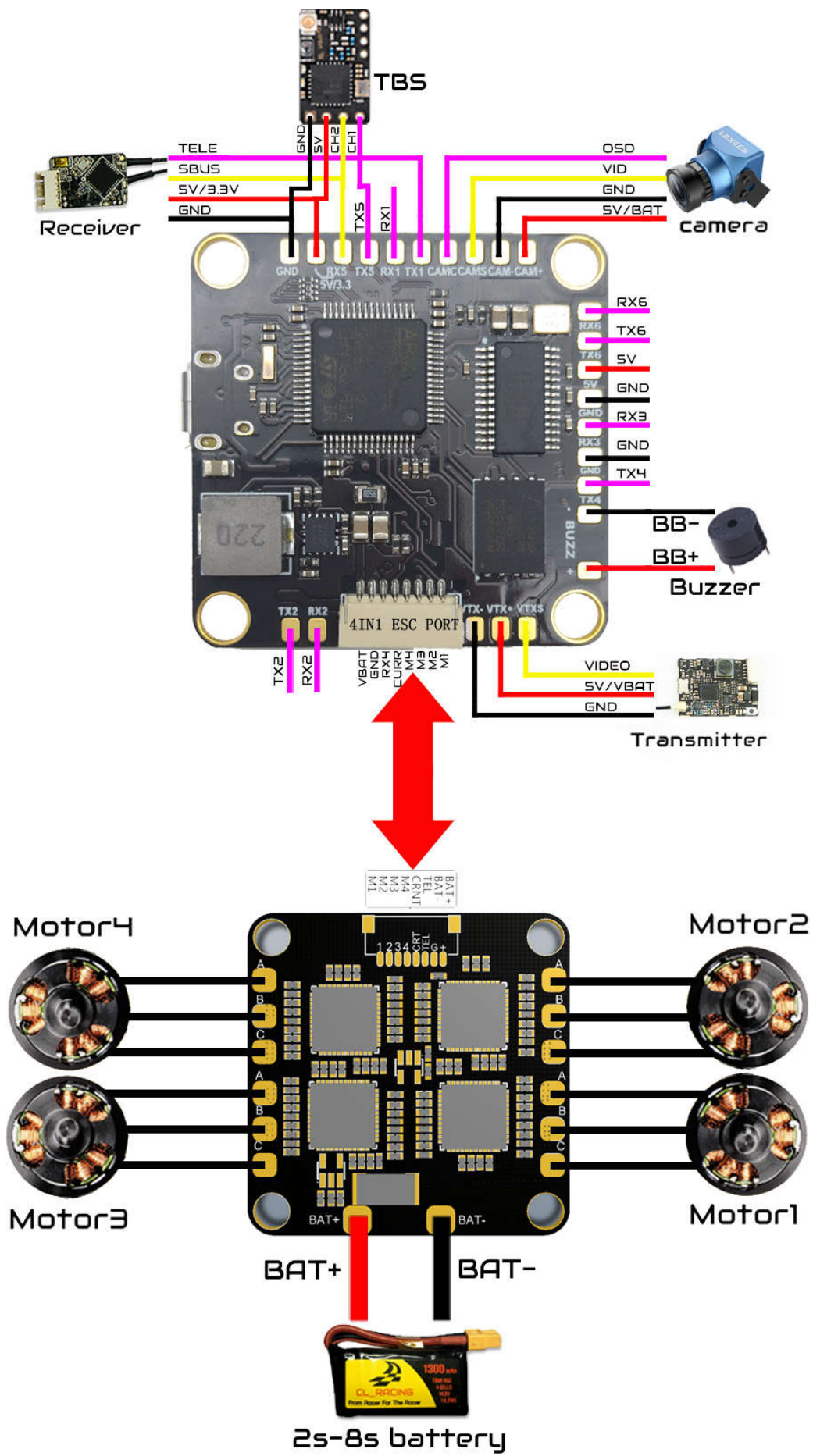

Pad Name	function	Pad Name	function
VBAT	POWER VBAT+	TX1	UART1 TX
GND	GROUND VBAT-	RX1	UART1 RX
CAM+	VBAT+ or 5V	TX2	UART2 TX
CAM-	GROUND VBAT-	RX2	UART2 RX
CAMC	CAMERA OSD PIN	TX3	UART3 TX
CAMS	CAMERA SIGNAL	RX3	UART3 RX
VTXS	VTX SIGNAL	TX4	UART4 TX
VTX+	VBAT+ or 5V	RX4	UART4 RX
VTX-	GROUND VBAT-	TX5	UART5 TX
LED_S	RGB LED SIGNAL	RX5	UART5 RX
BB+	BEEPER +	TX6	UART6 TX
BB-	BEEPER -	RX6	UART6 RX
ON	VTX POWER CONSTANT ON	5V	5V OUTPUT FROM FC
PIT	VTX POWER CONTROLABLE FROM RADIO		

BETAFLIGHT SETUP

1. Sbus

Choose UART 5 AS Serial RX, Solder your sbus signal to RX5 pad

Ports WIKI

Note: not all combinations are valid. When the flight controller firmware detects this the serial port configuration will be reset.
Note: Do NOT disable MSP on the first serial port unless you know what you are doing. You may have to reflash and erase your configuration if you do.

Identifier	Configuration/MSP	Serial Rx	Telemetry Output	Sensor Input	Peripherals
USB VCP	<input checked="" type="checkbox"/> 115200	<input type="checkbox"/>	Disabled AUTO	Disabled AUTO	Disabled AUTO
UART1	<input type="checkbox"/> 115200	<input type="checkbox"/>	SmartPort AUTO	Disabled AUTO	Disabled AUTO
UART2	<input type="checkbox"/> 115200	<input type="checkbox"/>	Disabled AUTO	Disabled AUTO	Disabled AUTO
UART3	<input type="checkbox"/> 115200	<input type="checkbox"/>	Disabled AUTO	Disabled AUTO	TBS SmartAut AUTO
UART4	<input type="checkbox"/> 115200	<input type="checkbox"/>	Disabled AUTO	Disabled AUTO	Disabled AUTO
UART5	<input type="checkbox"/> 115200	<input checked="" type="checkbox"/>	Disabled AUTO	Disabled AUTO	Disabled AUTO
UART6	<input type="checkbox"/> 115200	<input type="checkbox"/>	Disabled AUTO	Disabled AUTO	Disabled AUTO

Then in the configuration tab Choose

Receiver

Serial-based receiver (SPEKSAT, S) Receiver Mode

Note: Remember to configure a Serial Port (via Ports tab) and choose a Serial Receiver Provider when using RX_SERIAL feature.

SBUS Serial Receiver Provider

2. RX Voltage selection Jumper

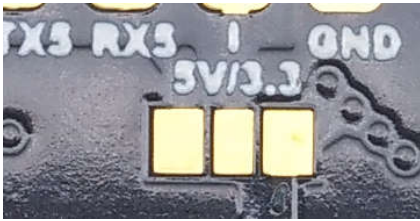

Solder on the left will output 5v , Solder the jumper on the right will output 3.3V

3. Smart port telemetry

Choose UART1 AS Smart port on the telemetry output, then go to CLI

Enter `set tlm_halfduplex = OFF`, Save

Identifier	Configuration/MSP	Serial Rx	Telemetry Output	Sensor Input	Peripherals
USB VCP	<input checked="" type="checkbox"/> 115200	<input type="checkbox"/>	Disabled AUTO	Disabled AUTO	Disabled AUTO
UART1	<input type="checkbox"/> 115200	<input type="checkbox"/>	SmartPort AUTO	Disabled AUTO	Disabled AUTO
UART2	<input type="checkbox"/> 115200	<input type="checkbox"/>	Disabled AUTO	Disabled AUTO	Disabled AUTO
UART3	<input type="checkbox"/> 115200	<input type="checkbox"/>	Disabled AUTO	Disabled AUTO	TBS SmartAux AUTO
UART4	<input type="checkbox"/> 115200	<input type="checkbox"/>	Disabled AUTO	Disabled AUTO	Disabled AUTO
UART5	<input type="checkbox"/> 115200	<input checked="" type="checkbox"/>	Disabled AUTO	Disabled AUTO	Disabled AUTO
UART6	<input type="checkbox"/> 115200	<input type="checkbox"/>	Disabled AUTO	Disabled AUTO	Disabled AUTO

4. Use True Pit mode for Team racing

VBAT and 5V jumper control both VTX power and Camera Power

First Solder Jumper pad on PIT side



Then go to CLI Copy the following command to the CLI

resource PINIO 1 A14

`set pinio_box = 39,0,0,0`

save

wait for the FC reboot then go to "modetab" "set VTX PIT MODE on a AUX switch you prefer



CAUTION: when using PIT mode, FC power up will not power your VTX until you turn on the switch on your radio you assigned to the VTX PIT mode

5. Use LEDS signal for Motor 4 enable RPM filtering

For normal use solder the jumper on the M4 side.



For RPM FILTERING

Solder Jumper pads to the LEDS side, Motor 4 signal in the 4 in 1 socket will connect to LED_S internally for rpm-filtering motor 4.

In the CLI type in:

```
resource MOTOR 4 none  
resource LEDS_STRIP 1 none  
resource motor 8 none  
resource MOTOR 4 B01  
save
```

now you can go ahead use the RPM filtering setting from BF wiki to enable RPM filtering feature