

SKYDROID 云卓

Quanzhou Skydroid Technology Co., Ltd.



*Tablet or mobile device not included

SKYDROID-T10 V1.0

User Manual

WARNING:

Misuse of this product may result in injury, damage or loss of property. Read the manual carefully before using this product. This item is not a toy. This item is intended for use by professional UAV operators and installers only. Do not use this product if you lack the knowledge and expertise to install and maintain UAV radio equipment. DO NOT use unapproved or unofficial components with this system. Operators must strictly follow the operation guides set forth in this manual. Skydroid does not accept any liability for the use or misuse of this product.

A.Description

1. Product features

① Dual antenna plus dual RF module with integrated control algorithms ensuring reliable communication via full angle high gain antennas. The T10 uses the Latest in FHSS (Frequency Hopping Spread Spectrum) technology to achieve perfect control and operation.

② Integrated with digital video transmission, farthest to 10KM.

③ Integrated with data transmission, farthest to 20KM.

④ Parameter adjustments via APP with upgraded traditional OSD to touch panel control.

⑤ Connected via Bluetooth or USB, also supports S.BUS、PPM、PWM、Serial ports and external devices, etc.

⑥ Connects the APP via Bluetooth, switching the operation model, adjusting the data of forward and reverse, rudder volume, channel binding, runaway protection value, SBUS, PPM output and digital baud rate. Providing parameter saving and loading functions.

⑦ Based on the "Tower"APP to ensure optimal compatibility with Pixhawk systems. A large map view allows for easy waypoint selection and route planning including one key return to home. The T10 Also supports Tower, QGC, JIYI, TOPXGUN and BOYING APP.

⑧ Using 2 pcs of 18650 batteries(Need buy separately),endurance over 20 hours with 20DBm transmission frequency.

⑨ High integrated datalink with video & data transmission and telemetry all in-one unit. Ultra-small size, with folding brackets, strong and stable.

⑩ A Number of optional cameras can be selected for your application, such as mini digital camera, digital camera with LED, 20 times zoom camera, etc.

2. Main application and range of usage

Specially designed for UAV, Helicopter, Fixed Wing, Multi Rotor or Boat operation. In video transmission (optional camera), Data Link and control of UAV.

3. TYPES, SPECIFICATION

PRODUCT DATA

Receiver data			
Model	R10	channels	10
Working voltage	4.5-5.5V	Working Current	100mA
Dimension	50*31*12(mm)	Weight	20g

Controller data			
Model	T10	channels	10
Working voltage	4.2V	Working Current	100mA
Frequency	2.400-2.483GHz	Modulation	New FHSS
Firmware	APP online	Weight	525g
Dimension	160*150*50mm	Battery Capacitor	4000mA
Duration	20(Hours)	Charge Port	MICRO-USB
Application	Helicopter,Fixed wing,Quadcopter,car,boat		

MINI Camera Specifications			
Model	MINIDCAM	Size	30*29*26mm
Working Current	180mA	Weight	15.6g

4. Order assignment

T10 Controller

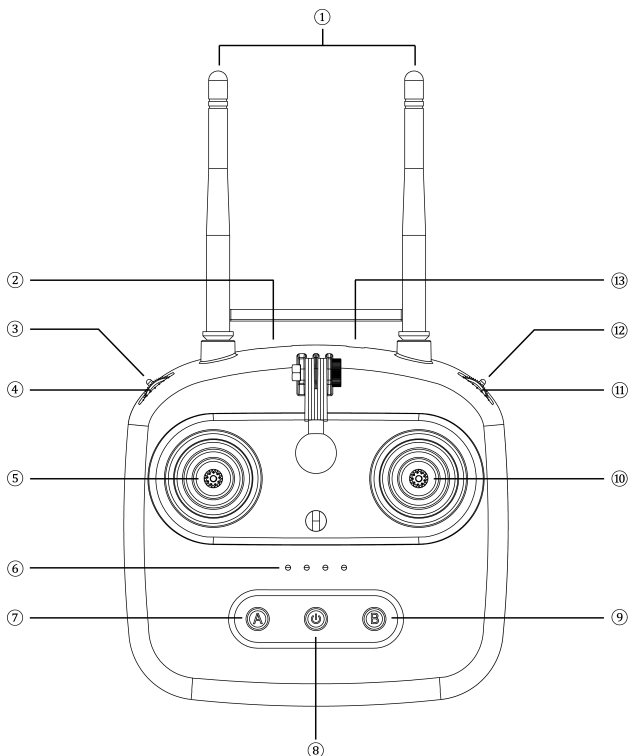

Number Description

Number	Description	Number	Description
1	2.4G 3dB Antenna	8	Power on/off button
2	USB1/video output	9	Button B
3	Three lever switch E	10	Right joystick X2、Y2
4	Jog wheel C	11	Jog wheel D
5	Left joystick X1,Y1	12	Three lever switch F
6	battery indicator①	13	Charging/data transmission
7	Button A		

① Battery Level LED definition ● ON ○ OFF

Battery Level LED definition				
●	●	●	●	75%-100%
●	●	●	○	50%-75%
●	●	○	○	25%-50%
●	○	○	○	0%-25%

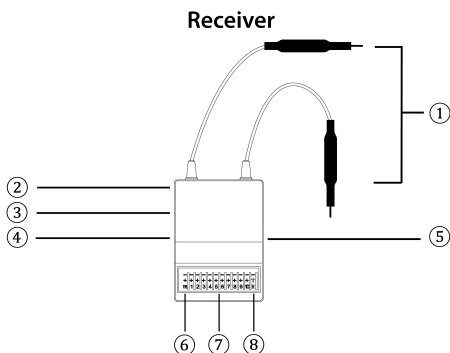

Port Description

Name	Description
1	Antenna
2	Power indicator
3	Pairing button
4	Firmware updating
5	Antenna
6	Power indicator
7	Pairing button
8	Firmware updating

Part List

Name	Qty	Remarks
T10 Main unit	1 piece	
R12 Receiver	1 piece	
MINIDCAM	1 piece	
Micro USB OTG cable	1 piece	For video transmission
Type C USB OTG cable	1 piece	For video transmission
Hexagon key	1 piece	For phone mount adjustment
Tools	1 piece	Change mode
Hanging strap	2 piece	
stick cap	2 piece	

Receiver indicator	Receiver status
Flashing in red	QC not passed, please return to factory
Red and green light rotates one time	QC passed
No green light on	No paired or main unit is off
Both color lights off	Checking the batteries' positive and negative

5. Environment Condition

PAY ATTENTION

- a) Environment Temperature: $-10^{\circ}\text{C} \sim +55^{\circ}\text{C}$.
- b) Storage Temperature: $-25^{\circ}\text{C} \sim +70^{\circ}\text{C}$.
- c) Relative Humidity: Do not exceed 85%.
- d) Atmospheric pressure: $86\text{kPa} \sim 106\text{kPa}$.
- e) Working environment should not contain explosive material or any corrosive or harmful gas that may cause interference in the operation of the product.
- f) Always work under shelter to prevent rain, snow, wind, sand and dust contamination.

6. Working Condition Power supply

Pay attention

The T10 main unit (ground terminal) uses two pieces of 18650 batteries, and compatible with the standard micro USB, 5v power adapter (such as mobile phone, camera and other digital products USB charger) to charge.

In case of smoke, heat or unusual an unusual smell during please stop charging the controller immediately and return to our company for servicing as soon as possible. Do not leave the product unattended while charging. Do not leave the product in a place where children can reach.

DO NOT charge when room temperature over 60°C .

7. Safety

WARNING

Beginners should pay attention for the following! Please read it carefully!

- ⊘ DO NOT fly under the influence of substances, or when tired!
- ⊘ DO NOT fly in strong wind and or rainy conditions!
- ⊘ DO NOT fly close to electric emission towers, communication stations and crowded area!
- ⊘ DO NOT fly nearby airports and other prohibited areas!
- ⊘ DO NOT fly around people or animals, or in any location where possible to damage property.
- ⚠ Check equipment before every flight and carry out maintenance and repairs as needed.
- ⚠ Use certified chargers to charge the batteries.
- ⚠ DO NOT put unnecessary force on antennas or electronic components to avoid damage.

B.Operation

Please connect Rx as below shown:

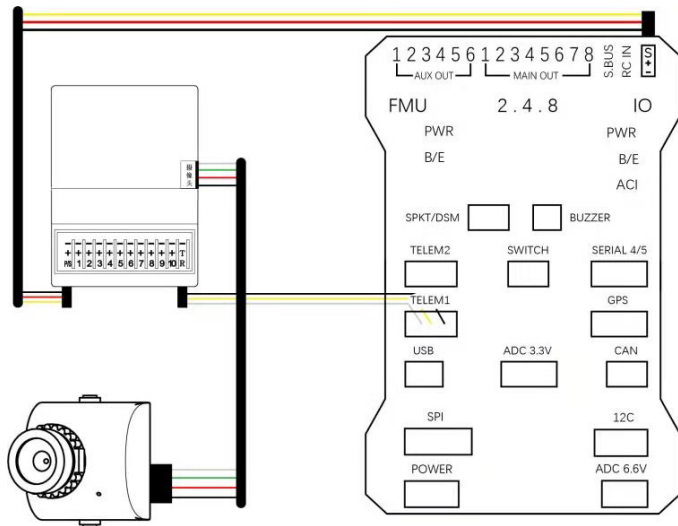

1. Pre-Check and Preparation

ATTENTION

- ① Check T12 battery level.
- ② Check position of the antenna to get better performance.
- ③ Make sure the firmware is the latest version.
- ④ DO NOT operate under the influence of alcohol or drug.

T10 part illustration Correct Position

Upright the antenna

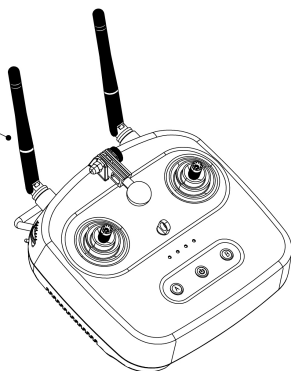

Incorrect operation

DO NOT put antenna parallel with the controller

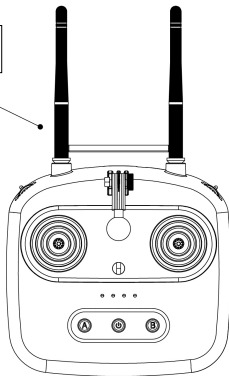

UAV Correct antenna position Correct Position

Place far from central board, upright the antenna without any obstacle

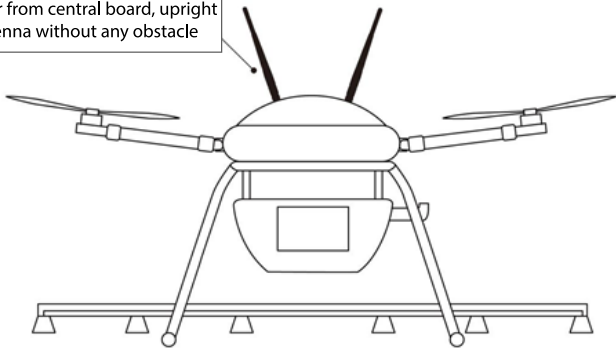

Or put under the drone arm

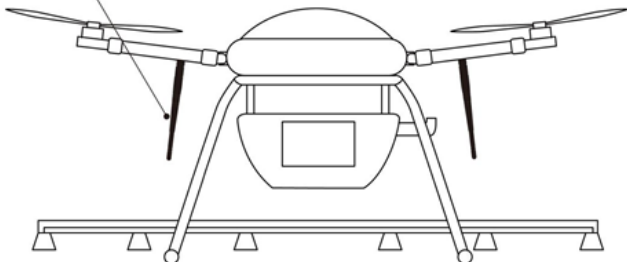

DO NOT put inside of the board

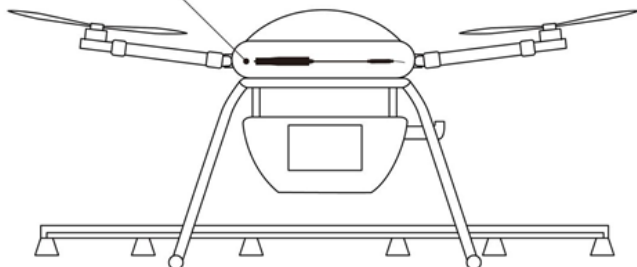

DO NOT place close to Carbon Fiber or Metal part

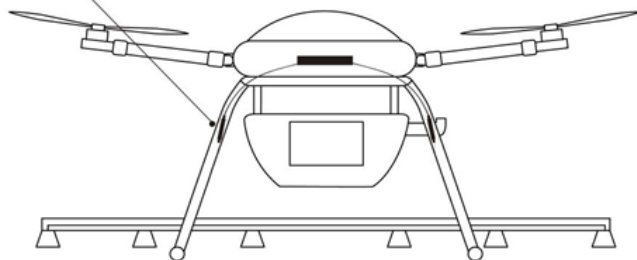

DO NOT cross the antenna between the central Flight control board and container

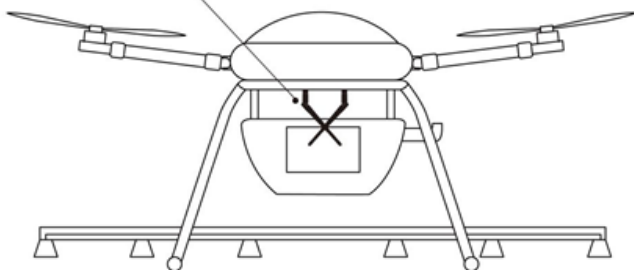

2. Operation

Part 1: Connect Device Helper

- 1) Confm receiver and fight controller are ready, power up to make sure the receiver is running normally.
- 2) Only support Android system.
- 3) Install APP (download from ofcial website www.skydroid.xin: Device Helper).
- 4) Turn on the T10 (short press + long time press), turn on Bluetooth on the phone and search. Find: T10-XXX, select and enter the pairing code 1234, then the connection is successful.

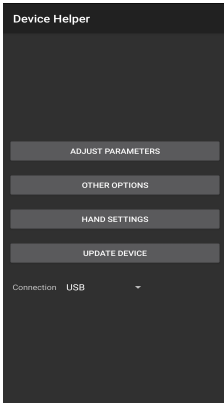

(1)

Name	Purpose
Adjust Parameters	Adjust channel Nor/Rev, Channel binding, Failsafe value
Other Options	For selection of sbus,ppm output and baud rate
Hand Settings	Support 4 different types of hand mode
Update Device	For online firmware upgrade

- 5) Adjust parameter: enter controller interface. APP read the current data of controller and receiver.(Diagram 2).

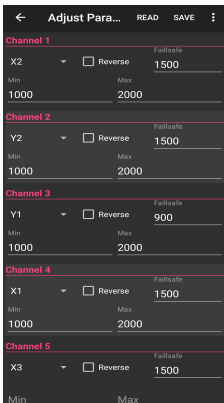

(2)

Example:

Channel 1: X2 has no Rev, Failsafe value is set to be 1500, min travel is 1000, max is 2000.

Channel 2: Y2 has no Rev, Failsafe value is set to be 1500, min travel is 1000, max is 2000.

Channel 3: Y1 has no Rev, Failsafe value is 900, min travel is 1000, max is 2000.

Channel 4: X1 has no Rev, Failsafe value is set to be 1500, min travel is 1000, max is 2000.

.....and vice versa, view adjustment horizontally is much easier for setting. Just tick related item.

Attention

- ① Please select the value between 900-2100, Failsafe hold select "0".
- ② Please click SAVE at the right upper corner to keep the record. The selected

value will be written to the controller and receiver.

6) Save and download the data (Diagram 3,4,5).

In order to quicker change from model to model, or large scale set up, we can save the data in the APP so that you can find it out easily.

As illustrated: when finished the adjustment, click " " then Save Configuration.

Then rename the model and save it. Same as download the data.

Attention: Adjusted parameter only save in the APP, Click "write" to load data to the controller. Sound "Di" means communication succeeded.

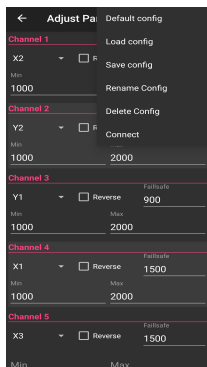

(3)

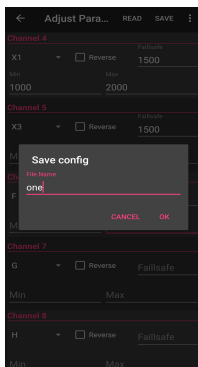

(4)

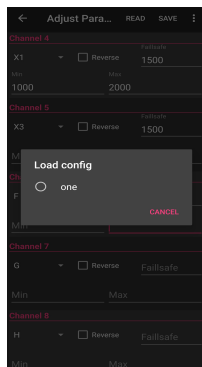

(5)

Part 2 : Receiver, Flight controller connection and set up

1) Binding: Press the pairing button on the side of the receiver and hold for 2 seconds, you can enter the pairing mode, then the green light will flashing. Meantime, turn on the main unit, can finish pairing. Once successful paired, the green indicate light will keep turning on.

2) Data link pin as illustrated, use attached wire or DIY connector to flight control board. Tx pin of receiver to Rx pin of Flight control board.

Part 3 : T10 Connect to Android phone

1) Connection between receiver and camera (example: mini digital camera), Power up the system. Please watch the video of connection in www.skydroid.xin.

2) Please go to www.skydroid.xin to download the Skydroid FPV.

3) Using Bluetooth to connect the T10 and the display (Please check the part No.1).

4) Click "Yes" to confirm then image will show on your phone.

5) Use of Skydroid FPV please go to the official website.

Part 4: How T10 connect to PC missionplanner, QGC

1) Use two USB connectors cable to link between USB1 and USB port in PC. Select the port related to the ground station. Please select Baud Rate 115200 to link with the data port of the flight controller. (QGC, missionplanner need to add SDK of Skydroid to show image, undevelopment).

2) Use Micro data cable to connect USB2 and PC, select baud rate 57600 (Only support data, not for video).

Part 5: How T10 to update firmware

1) Android update

Download and install Device Helper before upgrade.

2) T10 upgrade: connect T10 with the phone via Bluetooth, please check the part no.1.

Turn of the main unit, press and hold the button "A", and long time press the power button to turn it on, you will find button "A"'s light flashing slowly, which means, it is downloading. Meanwhile, open the Skydroid Device app to click "updating", choosing update the controller, and click "checking updating", if there's new firmware released, please click "update at once".

3) R10 update: connect R10 with the phone via Bluetooth, please make sure the main unit is turning on and paired with R10 (green indicate light turning on).

Open the Skydroid Device app to click "updating", choosing update the receiver, and click "checking updating", if there's new firmware released, please click "update at once".

Part 6: Q & A

Q: What is the Video/Data distance of T10 in transmission?

A: Under an open area, the max distance of video link is 10km while data link is 20km.

Q: Does T10 support ppm, sbus?

A: Yes! Sbus port is defaulted in the frst row. If you need ppm signal which can be switched in Device Helper App.

Q: How to defne two antenna on T10?

A: Two antenna are 2.4ghz redundant design. We use diversity technology so both antenna perform data link and transimission.

Q: How to defne two antenna on receiver?

A: Two antenna on Receiver are redundant design and telemetry.

Q:How to charge T10?

A: Use micro USB cable come with T10. Please use certified 5v charger. LED status: LED fashing during charging and of when it is full.

Q: Where to watch demonstration video of T10?

A: Please visit <http://www.skydroid.xin> and watch the video.

Q: How to power on/of the T10?

A: Short press and then long press the power switch.

Q: No LED indication on the receiver when plug into the fight control board?

A: T10 is power of; if the case still exist, check battery status(short press power switch to check the battery level), if not binding, then bind it.

Q: How to change Mode?

A: Monitor system linked up with the radio by Bluetooth, then open Device Helper to select mode 1 or mode 2 and saved. No need to set the others.

Q: How to calibrate neutral of the gimbal?

A: Calibration (watch video), please visit www.skydroid.xin.

Q: How many times of command being send out per second?

A: 300 times per second.

Q: Does T10 bind with new receiver?

A: T10 send binding signal with ID to bind a new receiver. Once binded the new one, old receiver need to rebind afterwards.

Q: what is the definition of the sound buzzer?

A: 3 short beep-power on. 4 short beep- binding succeeded,continues short beep-battery low level; slow continues beep-receiver not turn on or disconnected.

C. Maintenance, Servicing

Storage for not using certain period

Put T10 a dry and ventilated area. No direct Sun light to prevent harm to the internal Lipo battery. If store it over three months, it is highly recommended to put room temperature between 22C to 28C. DO NOT put it below 20C or higher than 45C area.

D. Transportation, Storage

WARNING

In order to prevent lost or getting hurt, Please strictly follow the rules of operation: Keep small parts or wire away from children can reach. DO NOT let children touch the small parts of T10.

ATTENTION

- 1) DO NOT put T10 into water. If it does, please switch of the power and dry it.
- 2) DO NOT crash the T10 or break the battery is prohibited.

E. Scan the QR code to download the APP

If download failed,search www.skydroid.xin



Device Helper



Skydroid FPV



Skydroid Tower

Device Helper—in use of adjustment of radio parameter, frmware upgrade, save models, mode change, etc.

Skydroid FPV—in use of linking Skydroid video, foating window can be top of others App(need to turn on foating window feature in Android system), use for VR, Video capture and Data rate adjustment).

Skydroid Tower—optimised by tower 4.0, can connect to mavlink protocol of APM,

PX4 flight controller to realise waypoint data telemetry. Also has video serial port (similar to DJI go).

ATTENTION

You need to wire connect with the Skydroid FPV to open the floating window. Activate QGC and connect with bluetooth to start telemetry. In the future, when QGC join Skydroid SDK then the operation will be as simple as Skydroid Tower. No need to connect bluetooth and no need to multiply another APP on QGC. Very simple. Highly recommend to use Skydroid tower.

FCC Statement

This equipment has been tested and found to comply with the limits for a Class B digital device, pursuant to Part 15 of the FCC Rules. These limits are designed to provide reasonable protection against harmful interference in a residential installation. This equipment generates uses and can radiate radio frequency energy and, if not installed and used in accordance with the instructions, may cause harmful interference to radio communications. However, there is no guarantee that interference will not occur in a particular installation. If this equipment does cause harmful interference to radio or television reception, which can be determined by turning the equipment of and on, the user is encouraged to try to correct the interference by one or more of the following.

measures:

- Reorient or relocate the receiving antenna.
- Increase the separation between the equipment and receiver.
- Connect the equipment into an outlet on a circuit diferent from that to which the receiver is connected.
- Consult the dealer or an experienced radio/TV technician for help.

This device complies with part 15 of the FCC Rules. Operation is subject to the following two conditions:

- (1) This device may not cause harmful interference.
- (2) This device must accept any interference received, including interference that may cause undesired operation.

Changes or modifications not expressly approved by the party responsible for compliance could void the user's authority to operate the equipment.

SKYDROID 云卓
Quanzhou Skydroid Technology Co., Ltd.



Facebook



YouTube

www.skydroid.xin