

GM72 Bar Code Reader Module User Manual



Hangzhou Grow Technology Co., Ltd.
V1.1 March.2018

Catalog

1 Introduction of Module.....	1
1.1 Introduction.....	1
1.2 Technical Specification.....	1
1.3 Dimension (mm).....	2
1.4 Circuit Board Diagram.....	3
2 Factory Mode Information.....	4
2.1 Factory Default Configuration.....	4
2.2 Setup Code.....	4
3 Communication Interface.....	5
3.1 Serial Port.....	5
3.1.1 Baud rate.....	5
3.1.2 Parity Bit.....	6
3.1.3 Stop Bit.....	6
3.2 USB KBW.....	6
3.3 USB COM Keyboard.....	6
4 Read Mode.....	7
4.1 Manual Mode.....	7
4.1.1 Button Holding Mode.....	7
4.1.2 Button Trigger Mode.....	7
4.2 Continuous Mode.....	7
4.2.1 Break Time Settlement.....	8
4.3 Induction Mode.....	8
4.3.1 Stable Induction Time.....	8
4.3.2 Sensitivity Rating Setting.....	9
4.4 Host Mode.....	9
4.5 Single scan time.....	9
4.6 Time Interval For The Same Code Read.....	10
5 Lighting and Collimate.....	10
5.1 Lighting.....	10
5.2 Collimation.....	10

6 Prompts.....	11
6.1 Keyboard Settlement.....	11
6.2 Prompts Tone.....	12
6.2.1 Silent Mode.....	12
6.2.2 Volume Level.....	12
6.2.3 Decoding Successful Prompt Tone.....	12
6.2.4 Starting Up Prompt.....	12
6.2.5 Setup Code Prompt.....	13
6.3 Decoding Prompt.....	13
6.4 Keyboard Output Force Letter Case Conversion.....	13
6.5 Data code format.....	14
7 Data Edition.....	15
7.1 CODE ID.....	15
7.2 Terminator Character.....	15
7.3 Add Prefix and Suffix.....	15
7.3.1 Define Prefix and Suffix Content.....	15
7.3.2 Define the Data Output Mode.....	16
8 All Types of Bar Code Can be Decoded.....	17
8.1 UPC-A.....	17
8.2 UPC-E.....	17
8.3 EAN-8.....	17
8.4 EAN-13.....	17
8.5 Bookland EAN.....	18
8.6 UPC/EAN Extracode.....	18
8.7 CODE 128.....	18
8.8 GS1-128.....	18
8.9 ISBT-128.....	19
8.10 Interleaved 2 of 5.....	19
8.10.1 I 2 of 5.....	19
8.10.2 Interleaved 2 of 5 Identify Length.....	19
8.10.3 Interleaved 2 of 5 Check Bit Transmission.....	19
8.11 Matrix 2 of 5.....	20
8.11.1 Matrix 2 of 5.....	20

8.11.2 Matrix 2 of 5 Identify Length.....	20
8.11.3 Matrix 2 of 5 Check Bit Transmission.....	20
8.12 Industrial 2 of 5.....	21
8.12.1 Industrial 2 of 5.....	21
8.12.2 Industrial 2 of 5 Identify Length.....	21
8.13 Standard 2 of 5.....	21
8.13.1 Standard 2 of 5.....	21
8.13.2 Standard 2 of 5 Identify Length.....	22
8.13.3 Standard 2 of 5 Check Bit Transmission.....	22
8.14 Code 39.....	22
8.14.1 Code 39.....	22
8.14.2 Code 39 Length.....	22
8.14.3 Code 39 Check Bit.....	23
8.14.4 Code39 Transmit Start Character and Stop Character.....	23
8.15 Code 39 Full ASCII.....	23
8.16 Code 93.....	23
8.17 Code 11.....	23
8.17.1 Code 11.....	23
8.17.2 Check Bit Transmission.....	24
8.18 Codabar.....	24
8.19 PLESSEY.....	24
8.20 MSI.....	24
8.21 GS1-Databar.....	25
8.22 QR Code.....	25
8.22.1 QR Code.....	25
8.22.2 Read More Yards.....	25
8.23 Data Matrix.....	25
8.23.1 Data Matrix.....	25
8.23.2 Data Matrix Read More Yards.....	26
8.24 PDF 417.....	26
8.25 Aztec Code.....	26
8.26 Maxi Code.....	26
9 Serial Port Instruction.....	27

10 Appendix 1: Digital Setting Code.....	30
11 Appendix 2: Cancel Barcode.....	31
12 Appendix 3: Code ID.....	32
13 Appendix 4: Character Comparison Table.....	33

1 Introduction of Module

1.1 Introduction

GM72 Bar code reader module is a high performance scanner, can read 1D bar code easily and read 2D bar code with high speed. It also wins high scan speed for linear code, even for bar code on paper or screen.

GM72 bar code reader module is an advanced bar code decoding algorithm which developed on image recognition algorithm, can easily and accurately read bar code, simplify secondary development.



1.2 Technical Specification

Scanning Performance	Scan Mode		640*480 CMOS
	Read Code Type	2D	QR Code, Data Matrix, PDF417,maxicode,Aztec,haxxin
		1D	EAN,UPC,Code 39,Code 93,Code 128,UCC/EAN 128, Codabar, Interleaved 2 of 5, Standard 25, MSI-Plessey GS1 Databar, Industrial 25, Matrix 2 of 5
	Accuracy of reading		One Dimensional Code:6mil
	Working Mode		Continuous Mode, Induction Mode, Manual Mode
	Depth of Field	Alipay	30-150mm
		Bus	50-120mm
	Contrast		≥25%
	Scanning angle		Intersection angle 360°, Elevation ± 55°, Deflection angle ± 55°
	Viewing Angle		Inclination 60°, Elevation 46°
Mechanical/ Electrical Parameters	Interface		TTL-232、 USB
	Dimension		65(W)×61(D)×28(H)mm
	Operating Current		DC5V≤100mA
Environmental Parameters	Operating Temperature		-20℃~+50℃
	Storage Temperature		-40℃~+70℃
	Operating Humidity		5%~95% (Non-Condensing)
	Environmental Light		0~100000LUX

1.3 Dimension (mm)

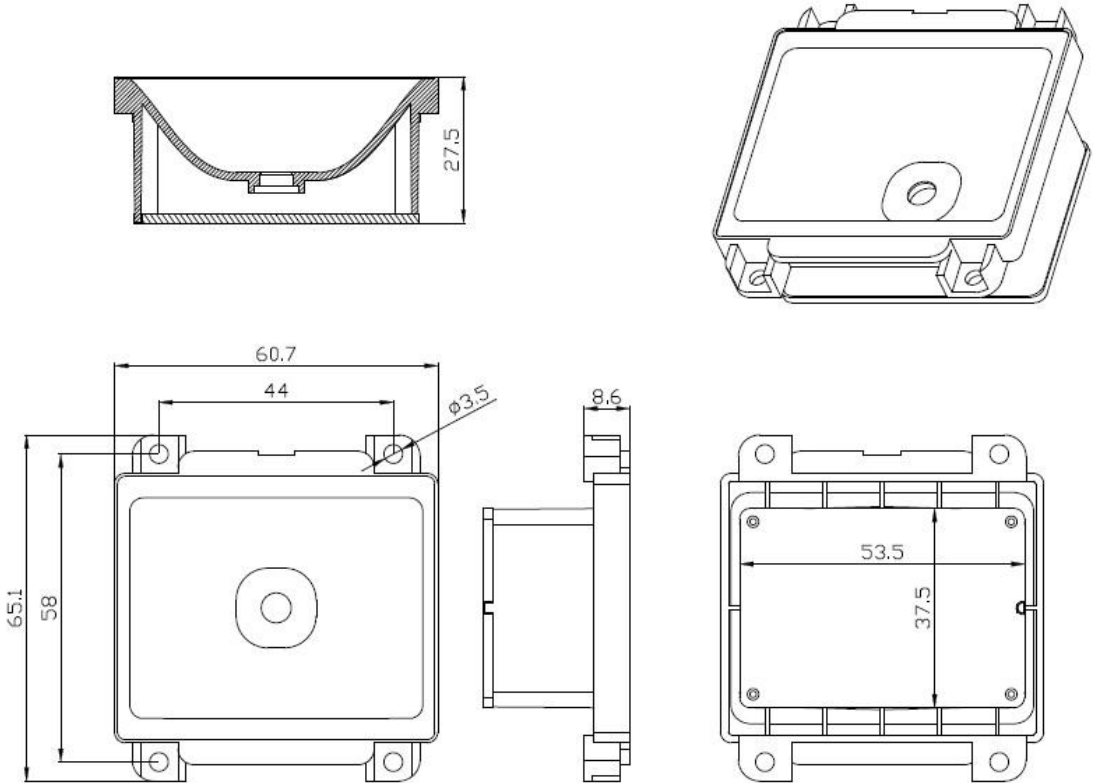

1.4 Circuit Board Diagram

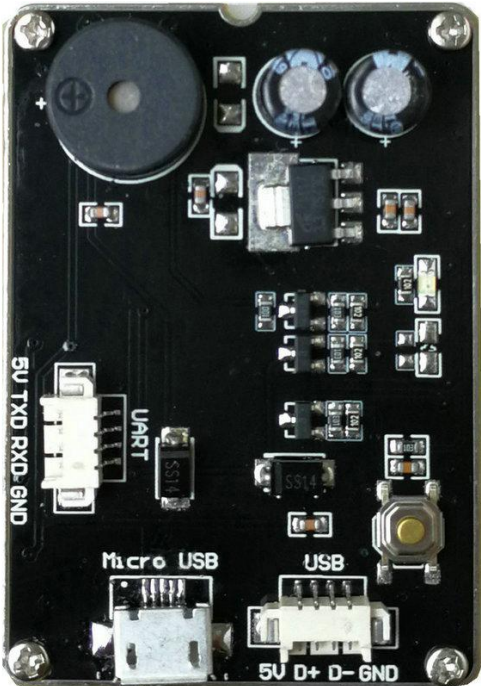
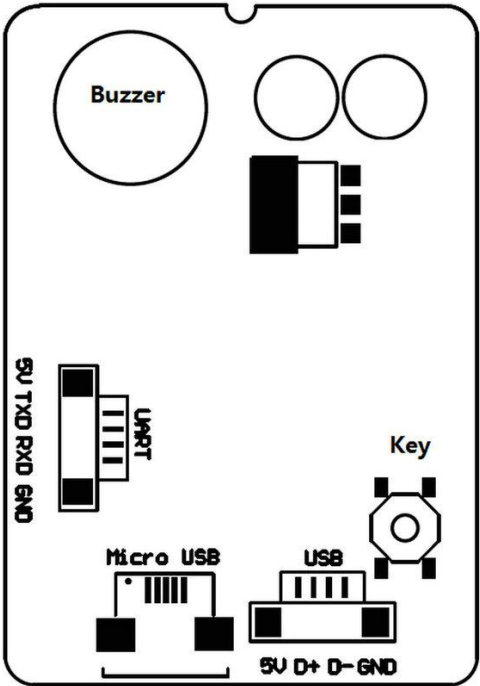

2 Factory Mode Information

2.1 Factory Default Configuration

Communication mode: USB KBW Trigger mode: Keep press the button Close: Enter(\r)



Factory default setting

2.2 Setup Code



*Setup code on



Off

3 Communication Interface

3.1 Serial Port

It's default and common to connect module and mainframe(such as PC, POS) by series communication interface. Make sure communication parameter for module and mainframe are same, then it will communicate smooth and correctly. **Serial port related configuration: Baud rate:9600, Data bit:8, Verification: No, Stop bit:1**



TTL 232 Interface

3.1.1 Baud rate



1200bps



2400bps



4800bps



*9600bps(Default)



19200bps



38400bps



57600bps



115200bps

3.1.2 Parity Bit



Odd number



Even number



*No parity

3.1.3 Stop Bit



*1 bit stop bit



2 bit stop bit

3.2 USB KBW



USB KBW Keyboard

3.3 USB COM Keyboard



USB COM

4 Read Mode

4.1 Manual Mode

4.1.1 Button Holding Mode

Set to button holding mode, press the button to trigger reading, and release the button to end reading. If the reading is successful or the reading time exceeds the single reading time, the reading will be finished.



***Manual Mode- Button Holding**

4.1.2 Button Trigger Mode

Set to the button trigger mode, press the button to start reading, release the button, read will not stop. If the reading is successful or the reading time exceeds the single reading time, the reading will be finished.



***Manual Mode- Button Trigger**

4.2 Continuous Mode

On this mode, reading module read code continuous and automatic. Read successfully or the reading time exceeds the single reading time, the reading will be finished, and automatically trigger the next reading.



Continuous Mode

4.2.1 Break Time Settlement

Time between two read.

Default:500ms, Unit:100ms, Range:0-9900ms

You can set the break time by scanning the bar code, example:

Set 0.5ms, first scan the bar code below. Then scan the “0” and “5” bar code in the Digital Setting Code (Appendix 1).



Break time settlement

4.3 Induction Mode

In automatic sensing mode, the reading engine detects the brightness of the surrounding environment. When the brightness changes, module will begin to read, read successfully or the reading time exceeds the single reading time, the reading will be finished. Regardless of the last read success or failure, the module will be redetects the brightness of the surrounding environment.



Induction Mode

4.3.1 Stable Induction Time

Stable time before entering the test environment. Default: 500ms, Unit:100ms, Range:0-9900ms

You can set the stable time by scanning the bar code, example:

Set 200ms, first scan the bar code below. Then scan the “0” and “2” bar code in the Digital Setting Code (Appendix 1).

Set 1500ms, first scan the bar code below. Then scan the “1” and “5” bar code in the Digital Setting Code (Appendix 1).



Stable Induction Time

4.3.2 Sensitivity Rating Setting

There are three levels of sensitivity to choose from, default: high sensitivity.



*High Sensitivity



Medium Sensitivity



Low Sensitivity

4.4 Host Mode

Through the instruction to trigger the reading engine, and it can end the reading by instruction, read successfully or the reading time exceeds the single reading time, the reading will be finished.



Host Mode

4.5 Single scan time

This parameter is the duration of a single decoding. Time from 0.5s to 25.5s, step size 0.1s. **Default 3s.** Example:

Set 0.5s, first scan the bar code below. Then scan the “0”, “0” and “5” bar code in the Digital Setting Code (Appendix 1).

Set 10.5s, first scan the bar code below. Then scan the “1”, “0” and “5” bar code in the Digital Setting Code (Appendix 1).



Single scan time

4.6 Time Interval For The Same Code Read

It means, after reading a barcode, refuse to read the same code for a set period of time. Only after a set period of time, it can be able to read and output. Default: 500ms, Unit:100ms, Range:0-9900ms.

Mainly for continuous mode and automatic induction mode.

Example: Set 0.5s, first scan the bar code below. Then scan the “0” and “5” bar code in the Digital Setting Code (Appendix 1).



Time Interval For The Same Code Read

5 Lighting and Collimate

5.1 Lighting

Head lamp is used to additional lighting when read.



*The light turn on only when read
(Default)



Always on



Always off

5.2 Collimation

There will be a pointing light beam which can help user to find best distance.



*The light turn on only when read
(Default)



Always on



Always off

6 Prompts

6.1 Keyboard Settlement

Scan following code to change keyboard.



*American English(Default)



Belgium



Finland



Germany



France



Italy



Sweden



UK



Denmark



Spain



Norway



Portugal



Turkey F



Turkey Q



Japan



Russia

6.2 Prompts Tone

6.2.1 Silent Mode



Close All Prompts



*Forbid to Close All Prompts

6.2.2 Volume Level

Default: high pitch



*High Pitch



Middle



Low

6.2.3 Decoding Successful Prompt Tone



*Decoding Successful Prompt Tone ON



Decoding Successful Prompt Tone OFF

6.2.4 Starting Up Prompt



*Starting Up Prompt ON



Starting Up Prompt OFF

6.2.5 Setup Code Prompt



***Setup Code Prompt ON**



Setup Code Prompt OFF

6.3 Decoding Prompt

If the barcode cannot be decoded within the timeout period before releasing the trigger button, it is allowed to send "unread" messages. Any possible prefix or suffix can be attached to this message.

When this function is disabled, no message can be sent to the host even if the barcode cannot be decoded.



***Forbid sending NR**



Allow sending NR

6.4 Keyboard Output Force Letter Case Conversion

Example: If the barcode is ab123dE, if scan the "convert to uppercase" bar code, the output is AB123DE; if scan the "convert to lowercase" bar code, the output is abc123de.

Default: Keyboard case is not converted.



***Keyboard case is not converted**



All uppercase



All lowercase



Case reversal

6.5 Data code format

Read following to print Chinese data according to specified code forma.

GBK format: notepad, EXCEL, UNICODE format: WORD and input box for chat tools.



GBK



Unicode

7 Data Edition

7.1 CODE ID

Users can identify different types of bar code by CODE ID.

CODE ID use one character to identify and can be self- defined. Pls see the Appendix 3.



***Not allowed to send ID**



Allowed to send ID

7.2 Terminator Character

Terminator character is add character format after decoding data: decoded data + terminator character.



***No Terminator**



#&CR LF



%CR



TAB

7.3 Add Prefix and Suffix

7.3.1 Define Prefix and Suffix Content

A prefix or suffix can be attached to the scan data for data editing.

Set these values to correspond to ASCII values that scan a four-digit number (that is, four bar codes). Pls see the Appendix 1 and Appendix 4.



Prefix



Suffix

7.3.2 Define the Data Output Mode



*NO Prefix and Suffix



Prefix+Data



Data+Suffix



Prefix+Data+Suffix

8 All Types of Bar Code Can be Decoded

8.1 UPC-A



*Allow



Forbid

8.2 UPC-E



*Allow



Forbid

8.3 EAN-8



*Allow



Forbid

8.4 EAN-13



*Allow



Forbid

8.5 Bookland EAN



Allow



*Forbid

8.6 UPC/EAN Extracode



*Don't read Extracode UPC/EAN Can Read Extracode UPC/EAN Only Read Extracode UPC/EAN

8.7 CODE 128



*Allow



Forbid

8.8 GS1-128



*Allow



Forbid

8.9 ISBT-128



***Allow**



Forbid

8.10 Interleaved 2 of 5

8.10.1 | 2 of 5



***Allow**



Forbid

8.10.2 Interleaved 2 of 5 Identify Length

Users can set to decode Interleaved 2 of 5 within a certain length range.

Example: Set to decode only Interleaved 2 of 5 within 4-20 bit length range.

First scan the bar code below, and then scan 0,4,2,0 bar code in Appendix 1 in sequence. Change the selection or cancel an incorrect input setting, scan the bar code in Appendix 2.



Industrial 2 of 5 within a certain length range



Industrial 2 of 5 in any length range

8.10.3 Interleaved 2 of 5 Check Bit Transmission



Allow



***Forbid**

8.11 Matrix 2 of 5

8.11.1 Matrix 2 of 5



Allow



*Forbid

8.11.2 Matrix 2 of 5 Identify Length

Users can set to decode Matrix 2 of 5 within a certain length range.

Example: Set to decode only Matrix 2 of 5 within 4-20 bit length range.

First scan the bar code below, and then scan 0,4,2,0 bar code in Appendix 1 in sequence. Change the selection or cancel an incorrect input setting, scan the bar code in Appendix 2.



Matrix 2 of 5 within a certain length range



Matrix 2 of 5 in any length range

8.11.3 Matrix 2 of 5 Check Bit Transmission



Allow



*Forbid

8.12 Industrial 2 of 5

8.12.1 Industrial 2 of 5



Allow



*Forbid

8.12.2 Industrial 2 of 5 Identify Length

Users can set to decode Industrial 2 of 5 within a certain length range.

Example: Set to decode only Industrial 2 of 5 within 4-20 bit length range.

First scan the bar code below, and then scan 0,4,2,0 bar code in Appendix 1 in sequence. Change the selection or cancel an incorrect input setting, scan the bar code in Appendix 2.



Industrial 2 of 5 within a certain length range



Industrial 2 of 5 in any length range

8.13 Standard 2 of 5

8.13.1 Standard 2 of 5



Allow



*Forbid

8.13.2 Standard 2 of 5 Identify Length

Users can set to decode Standard 2 of 5 within a certain length range.

Example: Set to decode only Standard 2 of 5 within 4-20 bit length range.

First scan the bar code below, and then scan 0,4,2,0 bar code in Appendix 1 in sequence. Change the selection or cancel an incorrect input setting, scan the bar code in Appendix 2.



Standard 2 of 5 within a certain length range



Standard 2 of 5 in any length range

8.13.3 Standard 2 of 5 Check Bit Transmission



Allow



*Forbid

8.14 Code 39

8.14.1 Code 39



*Allow



Forbid

8.14.2 Code 39 Length



Can solve for any length of code39

8.14.3 Code 39 Check Bit



Transmission Check Bit



No check bits are transmitted

8.14.4 Code39 Transmit Start Character and Stop Character



Allow



*Forbid

8.15 Code 39 Full ASCII



Allow



*Forbid

8.16 Code 93



Allow



*Forbid

8.17 Code 11

8.17.1 Code 11



Allow



*Forbid

8.17.2 Check Bit Transmission



Allow



*Forbid

8.18 Codabar



Allow



*Forbid

8.19 PLESSEY



Allow



*Forbid

8.20 MSI



Allow



*Forbid

8.21 GS1-Databar



Allow



*Forbid

8.22 QR Code

8.22.1 QR Code



Allow



*Forbid

8.22.2 Read More Yards



Only Read Single Code



Only read Dicode



Single and Dicode can be recognized

8.23 Data Matrix

8.23.1 Data Matrix



*Allow



Forbid

8.23.2 Data Matrix Read More Yards



Only Read Single Code



Only read Dicode



Single and Dicode can be recognized

8.24 PDF 417



*Allow



Forbid

8.25 Aztec Code



Allow



*Forbid

8.26 Maxi Code



Allow



*Forbid

9 Serial Port Instruction

When the scanner is not working, it is in sleep mode. Under the sleep mode, need to wake up first, then send the effective instruction (send wake up instruction : 0x00, then send effective instruction after 50ms). To start decoding and stop decoding the serial port command needs to be valid in host mode. Please switch to the host mode first.

	Function	Parameter	Setup and Operation Instructions (Hexadecimal)	ACK
General Command	1. Set Default Parameters	Restore Factory Default Configuration	08 C6 04 08 00 F2 FF 00 FD 35	04 D0 00 00 FF 2C
	2. Check Software Version	Back to current version information	04 A3 04 00 FF 55	Back to version information
	3. Decode start and stop Settings	Start decode		04 E4 04 00 FF 14
Stop decode			04 E5 04 00 FF 13	
Mode	4. Trigger Mode	Host	07 C6 04 08 00 8A 08 FE 95	04 D0 00 00 FF 2C
		Level (Key Holding)	07 C6 04 08 00 8A 00 FE 9D	
		Pulse (Single Trigger)	07 C6 04 08 00 8A 02 FE 9B	
		Continuous Mode	07 C6 04 08 00 8A 04 FE 99	
		Automatic Induction Mode	07 C6 04 08 00 8A 09 FE 94	
communication	5. Communication Mode	Serial Port	08 C6 04 08 00 F2 01 00 FE 33	04 D0 00 00 FF 2C
		USB KBW (USB Keyboard Port)	08 C6 04 08 00 F2 01 01 FE 32	
		USB Serial Port	08 C6 04 08 00 F2 01 02 FE 31	
	6. Baud Rate	4800	07 C6 04 08 00 9C 05 FE 86	
		9600	07 C6 04 08 00 9C 06 FE 85	
		19200	07 C6 04 08 00 9C 07 FE 84	
		38400	07 C6 04 08 00 9C 08 FE 83	
		57600	07 C6 04 08 00 9C 09 FE 82	
		115200	07 C6 04 08 00 9C 0A FE 81	
	Output Format	7. Terminator Setting	Forbid	
CR LF			08 C6 04 08 00 F2 05 01 FE 2E	
CR			08 C6 04 08 00 F2 05 02 FE 2D	
TAB			08 C6 04 08 00 F2 05 03 FE 2C	
CR CR			08 C6 04 08 00 F2 05 04 FE 2B	

		CR LF CR LF	08 C6 04 08 00 F2 05 05 FE 2A
Light Setting	8. Lamp Control	Turn on only read(Default)	08 C6 04 08 00 F2 02 00 FE 32
		Always on	08 C6 04 08 00 F2 02 01 FE 31
		Always off	08 C6 04 08 00 F2 02 02 FE 30
	9. Positioning light control	Turn on only read(Default)	08 C6 04 08 00 F2 03 00 FE 31
		Always on	08 C6 04 08 00 F2 03 01 FE 30
		Always off	08 C6 04 08 00 F2 03 02 FE 2F
10. Decoding successful signal lamp	Allow(Default)	08 C6 04 08 00 F2 0B 01 FE 28	
	Forbid	08 C6 04 08 00 F2 0B 00 FE 29	
Sound Setting	11. Mute/Allow or forbid close all prompts	Forbid(Default)	08 C6 04 08 00 F2 0C 00 FE 28
		Allow	08 C6 04 08 00 F2 0C 01 FE 27
	12. Buzzer Voice	High(Default)	07 C6 04 08 00 8C 00 FE 9B
		Middle	07 C6 04 08 00 8C 01 FE 9A
		Low	07 C6 04 08 00 8C 02 FE 99
	13. Starting Up Prompt	Allow(Default)	08 C6 04 08 00 F2 0D 01 FE 26
		Forbid	08 C6 04 08 00 F2 0D 00 FE 27
	14. Setup Code Prompt	Allow(Default)	08 C6 04 08 00 F2 0E 01 FE 25
Forbid		08 C6 04 08 00 F2 0E 00 FE 26	
15. Decoding Prompt	Allow(Default)	07 C6 04 08 00 38 01 FE EE	
	Forbid	07 C6 04 08 00 38 00 FE EF	
Time Setting	16. Scanning duration (n*100ms) Default: 3000ms Range: 500-2550	5	07 C6 04 08 00 88 05 FE 9A
		10	07 C6 04 08 00 88 0A FE 95
		30	07 C6 04 08 00 88 1E FE 81
		50	07 C6 04 08 00 88 32 FE 6D
		100	07 C6 04 08 00 88 64 FE 3B
		150	07 C6 04 08 00 88 96 FE 09
		200	07 C6 04 08 00 88 C8 FD D7
		Infinite	07 C6 04 08 00 88 00 FE 9F

	0ms		
	17.	0	08 C6 04 08 00 F3 02 00 FE 31
	Stable	1	08 C6 04 08 00 F3 02 01 FE 30
	Inductio	3	08 C6 04 08 00 F3 02 03 FE 2E
	n time	5	08 C6 04 08 00 F3 02 05 FE 2C
	(n*100m s)		
	Default: 500ms	10	08 C6 04 08 00 F3 02 0A FE 27
	Range: 0-9900ms		
	18.	0	07 C6 04 08 00 89 00 FE 9E
	Break	1	07 C6 04 08 00 89 01 FE 9D
	Time	3	07 C6 04 08 00 89 03 FE 9B
	Settleme	5	07 C6 04 08 00 89 05 FE 99
	nt	10	07 C6 04 08 00 89 0A FE 94
	(n*100m s)	15	07 C6 04 08 00 89 0F FE 8F
	Default: 500ms	20	07 C6 04 08 00 89 14 FE 8A
	Range: 0-9900ms		
	19.	0	08 C6 04 08 00 F3 03 00 FE 30
	Time	1	08 C6 04 08 00 F3 03 01 FE 2F
	Interval	3	08 C6 04 08 00 F3 03 03 FE 2D
	For The	5	08 C6 04 08 00 F3 03 05 FE 2B
	Same	10	08 C6 04 08 00 F3 03 0A FE 26
	Code	15	08 C6 04 08 00 F3 03 0F FE 21
	Read		
	(n*100m s)		
	Default: 500ms	20	08 C6 04 08 00 F3 03 14 FE 1C
	Range: 0-9900ms		
Setting Limit	20.	Allow(Default)	07 C6 04 08 00 EC 01 FE 3A
	Allows scanning of configur ation codes	Forbid	07 C6 04 08 00 EC 00 FE 3B

10 Appendix 1: Digital Setting Code



0



1



2



3



4



5



6



7



8



9

11 Appendix 2: Cancel Barcode

Change the selection or cancel an incorrect input, scan the bar code below.



Cancel

12 Appendix 3: Code ID

Code Characters	Bar code Type
A	UPC-A, UPC-E, EAN-8, EAN-13
B	Code 39, Code 32
C	Codabar
D	Code 128, ISBT 128
E	Code 93
F	Interleaved 2 of 5
G	Discrete 2 of 5
H	CODE11
J	MSI, MSI/Plessey
K	GS1-DataBar, /UCC/EAN-128
L	Bookland EAN, Bookland EAN/ISBN
M	Trioptic Code 39
N	Coupon Code
R	GS1 DataBar-14, GS1 DataBar Limited, GS1 DataBar Expanded, RSS
S	SETUP128
r	PDF417
u	DataMatrix(DM)
q	QR
a	Aztec Code
x	Maxi Code
v	Veri Code
C	HanXin

13 Appendix 4: Character Comparison Table

Scanning Value	Keyboard Value	Scanning Value	Keyboard Value	Scanning Value	Keyboard Value
1000	Null	1043	+	1086	V
1001	Keypad Enter	1044	,	1087	W
1002	Caps lock	1045	-	1088	X
1003	Right Arrow	1046	.	1089	Y
1004	Up Arrow	1047	/	1090	Z
1005	Null	1048	0	1091	[
1006	Null	1049	1	1092	\
1007	Enter	1050	2	1093]
1008	Left Arrow	1051	3	1094	^
1009	Horizontal Tab	1052	4	1095	_
1010	Down Arrow	1053	5	1096	'
1011	Vertical Tab	1054	6	1097	a
1012	Backspace	1055	7	1098	b
1013	Enter	1056	8	1099	c
1014	Insert	1057	9	1100	d
1015	Esc	1058	:	1101	e
1016	F11	1059	;	1102	f
1017	Home	1060	<	1103	g
1018	Print Screen	1061	=	1104	h
1019	Delete	1062	>	1105	i
1020	tab+shift	1063	?	1106	j
1021	F12	1064	@	1107	k
1022	F1	1065	A	1108	l
1023	F2	1066	B	1109	m
1024	F3	1067	C	1110	n
1025	F4	1068	D	1111	o
1026	F5	1069	E	1112	p
1027	F6	1070	F	1113	q

1028	F7	1071	G	1114	r
1029	F8	1072	H	1115	s
1030	F9	1073	I	1116	t
1031	F10	1074	J	1117	u
1032	Space	1075	K	1118	v
1033	!	1076	L	1119	w
1034	“	1077	M	1120	x
1035	#	1078	N	1121	y
1036	\$	1079	O	1122	z
1037	%	1080	P	1123	{
1038	&	1081	Q	1124	
1039	‘	1082	R	1125	}
1040	(1083	S	1126	~
1041)	1084	T		
1042	*	1085	U		