

**Hanvon®**



**Go Go Bird™**

**User Manual**

[www.gogobird.com](http://www.gogobird.com)

# Contents

1. Go Go Bird & Accessories.....	1
2. Flight Preparation.....	3
3. Flight Operation.....	7
4. Troubleshooting.....	12
5. Wireless Control Information.....	12
6. Tips & Tricks.....	13
7. Warnings.....	14

# 1. Go Go Bird & Accessories

## Go Go Bird(Go Go Bird 102)

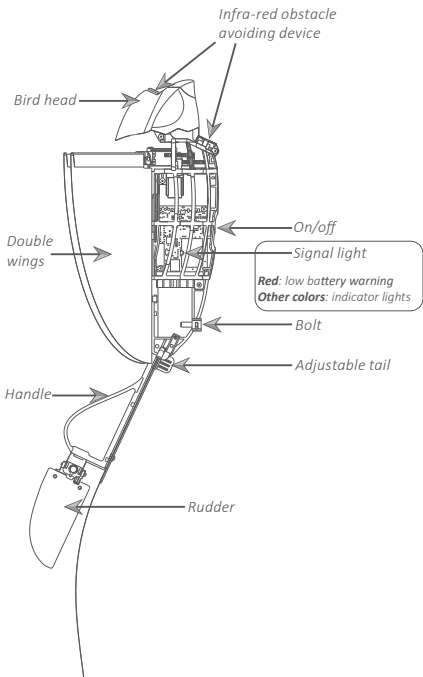

## Remote control (FYC 102)

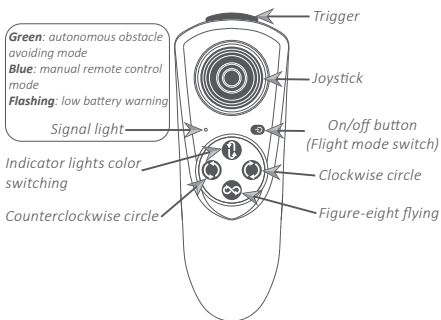

## Screwdriver



## Lithium batteries

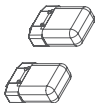

## USB charger





## 2. Flight preparation

### a. Go Go Bird lithium battery

How to charge lithium battery:

Insert lithium battery into USB charger (figure 1), connect the charger to an adaptor, computer, or any DC 5.0V USB charging port.

Two LED indicator lights will illuminate. The green light indicates that the power source is working and the red light indicates that the battery is charging.

When charging is complete, the red light will turn off. Unplug the USB charger from power source and remove the lithium battery promptly. (Charging time is around 20 mins, flight duration is around 10 mins)



Figure 1 Charge lithium battery

When Go Go Bird's signal light turns red, the lithium battery is running low. Replace the exhausted lithium battery as soon as possible. (figure 2)

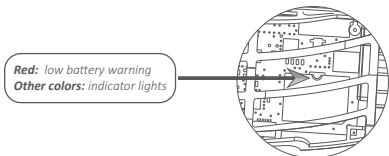

Figure 2 The battery signal light

## How to install lithium battery into Go Go Bird:

First use the screwdriver to rotate the bolt located at the bottom of Go Go Bird 90 ° counterclockwise and remove it (figure 3); Then plug the fully charged lithium battery into the slot (figure 4), make sure the lithium battery is completely connected to the electric socket.

Replace the bolt and turn it 90 ° clockwise to lock the battery into place (figure 5).

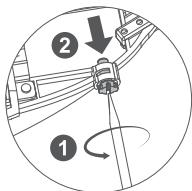

Figure 3 Remove the bolt

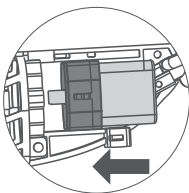

Figure 4 Install lithium battery

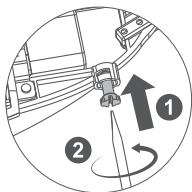

Figure 5 Fasten the bolt

## **b. Remote control**

Use the screwdriver to remove remote control battery compartment cover (figure 6), two 1.5V AAA batteries are to be inserted into remote control with the correct polarity, then replace the cover and tighten the screw afterwards.

Press the on/off button to turn remote control on , hold the on/off button until the signal light turns off to turn remote control off. The remote control will turn off automatically if there is no input for 12 mins.

The signal light will start to flash when AAA batteries are running out of power. If Go Go Bird is currently flying, land it before replacing the batteries . The signal light will flash for 30 seconds before remote control goes out automatically.

Exhausted AAA batteries are to be removed from remote control battery compartment cover immediately.

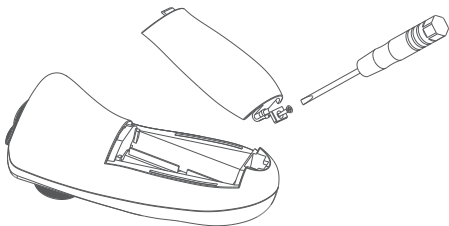

*Figure 6 Open battery compartment cover*

### c. Pairing Go Go Bird with remote control

Your Go Go Bird should already be paired with the remote control, but if you are experiencing connectivity issues, please refer to below pairing steps.

1: Turn on the switch of Go Go Bird and check to see that the green signal light is on.

2: Place the remote control close to Go Go Bird.

3: Start with remote control off, while holding the top trigger button and the bottom  button at the same time, then press on/off button to turn the remote control on (figure 7).

4: Go Go Bird's signal light should be flashing indicating that the pairing was successful.

5: If it fails to match, please repeat above steps.

6: If the remote control is off, Go Go Bird will automatically stop flapping its wings.

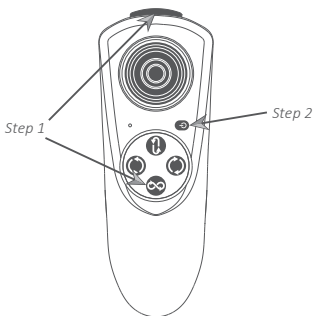

Figure 7 Buttons for pairing step

### 3. Flight operation

#### a. 2 methods to begin flight

Turn on the on/off switch of Go Go Bird and remote control.

Method 1: by somatosensory switch

Hold Go Go Bird horizontally (figure 8) and drop your arm about 12" until the wings start to flap. Repeat if Go Go Bird doesn't start flapping. Gently toss Go Go Bird forward to begin flight.

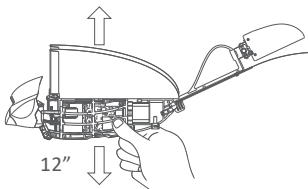

Figure 8 Turn on Go Go Bird by somatosensory switch

Turn Go Go Bird off by turning it upside down. The wings will stop flapping immediately (figure 9).

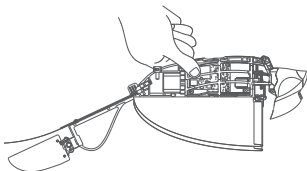
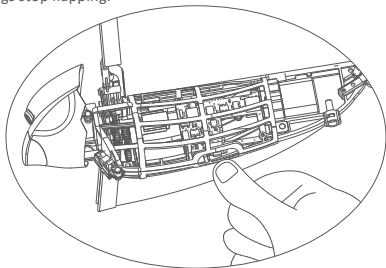

Figure 9 Turn off Go Go Bird by somatosensory switch

## Method 2: by remote control

Hold Go Go Bird horizontally (figure 10) and press the trigger button on the remote control (figure 10) to make the wings begin to flap. Gently toss Go Go Bird forward to begin flight.

Press the top trigger button again (figure 11) to make the wings stop flapping.



*Figure 10 Hold Go Go Bird horizontally*

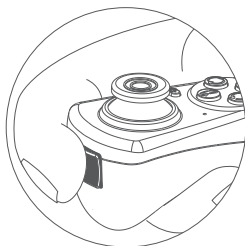

*Figure 11 Turn on/off Go Go Bird by remote control*

## b. Flight modes

Go Go Bird has two different flight modes: autonomous obstacle avoidance mode and manual remote control mode.

When in autonomous obstacle avoidance mode, Go Go Bird will automatically turn to avoid a collision without remote control operation when it senses an obstacle. It may have some troubles detecting and avoiding transparent, dark, or small objects.

Autonomous obstacle avoidance mode is on by default when you turn Go Go Bird on and the signal light on remote control will be green.

To switch to manual remote control mode, tap the on/off button (remote control should be on). The signal light on remote control will turn blue. You will need to guide Go Go Bird away from obstacles manually (figure 12).

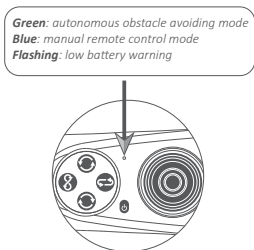



Figure 12 The signal light on remote control

You can assign your Go Go Bird signal light a unique color when flying with other Go Go Birds to help distinguish them from each other. Press the  button on the remote control to change the signal light color (figure 13). Press it again until you arrive at the color you want.

*The light can be green, yellow, blue, cyan, magenta, white, or set to flash while cycling through all the colors.*

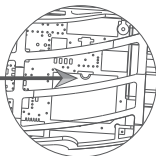







Figure 13 The signal light on Go Go Bird

### c. How to monitor remote control

Trigger Button	Start/Stop flapping wings
Move Joystick Upwards	Speed Up
Move Joystick Downwards	Slow Down
Move Joystick Left/Right	Move Left/Right
	Fly in a clockwise circle until another command is given
	Fly in a counterclockwise circle until another command is given
	Switch indicator light color
	Fly in a figure-eight
	Hold to turn ON/OFF, tap to switch flight modes



Go Go Bird is with altitude hold sensor, when you fly Go Go Bird, please hold it higher with your hand then release, Go Go Bird will be on auto fly mode.

The default setting for Go Go Bird is to fly straight and at the same altitude at which it was released. Move the joystick in any direction to control the flight.

Go Go Bird's flight speed can be set by manually adjusting the tab near Go Go Bird's tail. Push the tab all the way for high speed flight (figure 14). Pull the tab back until you hear a click for low speed flight (figure 15).

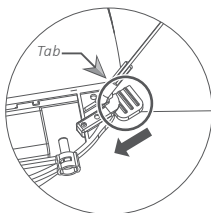

*Figure 14 High speed flight gear*

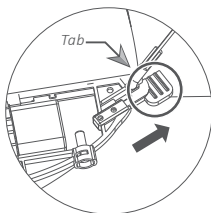

*Figure 15 Low speed flight gear*

## 4. Troubleshooting

### a. No response when turning on the remote control

Solution: Double check whether the batteries install correctly according to the polarity identification, or replace with new AAA batteries.

### b. No response or lack of power when turning on Go Go Bird

Solution: 1) Double check whether lithium battery fully inserted into Go Go Bird battery compartment; 2) Make sure the lithium battery of Go Go Bird is fully charged.

### c. Remote control fails to control Go Go Bird

Solution: Turn Go Go Bird and remote control off, repeat the pairing steps.

## 5. Wireless Control Information

Product: Bionic flapping-wing bird

Declaration for EU Compliance

Frequency bands: 2424~2472 MHz

Max. Output Power: -0.56dBm (remote control), 3.64dBm (bird)

## 6. Tips & Tricks

★ Get longer flight times by increasing altitude then slowing down to maintain level flight.

★ Spirals are fun, you can also keep spinning to lower your altitude.

★ Swoop there it is! While flying, turn off the wings to watch the Go Go Bird start to glide to the ground, turn it on quickly again and it will swoop!

★ Turning any direction after a swoop prevents a stall and looks super cool.

★ The best way to gain height is to fly straight and at full speed.

★ Charge your extra battery while flying so you can swap once the current battery is low.

★ Remember the controls seem reversed when the bird is flying toward you.

★ When launching Go Go Bird into the sky, don't throw it, gently push it away from you.

★ Table Launch! Place the Go Go Bird upside-down on the edge of a table and double tap the trigger button to watch the Go Go Bird flip over and fly off the table!

★ When your Go Go Bird's red light starts blinking the battery is low, it's best to land it and grab that extra battery.

★ When you play outdoor, it is not recommend to use when wind speed outside  $\geq$  Level 3 (12–19 km/h).

## 7. Warnings

★ When removing Go Go Bird from the box, try not to grab the wings and tail (Figure 16). Keep Go Go Bird away from sources of heat and sharp objects.

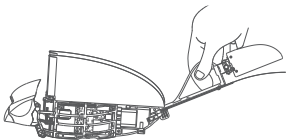

Figure 16 Grab the handle to take Go Go Bird out

★ When playing with multiple Go Go Birds, pair each one individually. Do not turn on the switch for two or more Go Go Birds and pair with the remote controls at the same time.

★ Please keep Go Go Bird in sight when flying. Avoid water, trees, power lines, etc.

★ Press the trigger button in an emergency to make Go Go Bird stop flying and land immediately. Check the wires, battery, shell, and other parts regularly. If there is damage, do not use it until it is repaired.

★ This product is not suitable for children under 3 years old. Please keep the user manual and package box at all times since they contain important information.

★ Please use the customized lithium batteries that come with Go Go Bird only. Do not match with other lithium batteries. Rechargeable batteries are only to be charged under adult supervision. Rechargeable batteries are to be removed from the toy before being charged.

★ AAA batteries are to be inserted into remote control with

the correct polarity. Non-chargeable batteries are not to be charged. Different types of batteries or new and used batteries are not to be mixed. Exhausted batteries are to be removed from the toy. The supply terminals are not to be short-circuited. Do not mix old and new batteries. Do not mix alkaline, standard (carbon-zinc), or rechargeable batteries.

★For lithium battery, kindly pay attention to below

☆Keep small cells and batteries which are considered swallowable out of reach of children.

☆ Swallowing may lead to burns, perforation of soft tissue, and death. Severe burns can occur 2 h of ingestion.

☆ In case of ingestion of a cell or battery, seek medical assistance promptly.

☆ Do not disassemble. Do not short circuit.

☆ Do not dispose of in fire.

☆Do not expose to high temperature (60°C/140°F).

☆Do not open. Do not crush.

★FCC Compliance

This device complies with Part 15 of the FCC Rules. Operation is subject to the following two conditions: (1) this device may not cause harmful interference, and (2) this device must accept any interference received, including interference that may cause undesired operation.

Note: This equipment has been tested and found to comply with the limits for a Class B digital device, pursuant to Part 15 of the FCC Rules. These limits are designed to provide reasonable protection against harmful interference in a residential installation. This equipment generates, uses and can radiate radio frequency energy and, if not installed and used in accordance with the instructions, may cause harmful interference to radio communications. However, there is no

guarantee that interference will not occur in a particular installation.

If this equipment does cause harmful interference to radio or television reception, which can be determined by turning the equipment off and on, the user is encouraged to try to correct the interference by one or more of the following measures:

☆ Reorient or relocate the receiving antenna.

☆ Increase the separation between the equipment and receiver.

☆ Connect the equipment into an outlet on a circuit different from that to which the receiver is connected.

☆ Consult the dealer or an experienced radio/TV technician for help.

Caution: changes or modifications not expressly approved by the party responsible for compliance could void the user's authority to operate the equipment.

#### ★ ISED Regulatory Compliance

This device contains licence-exempt transmitter(s)/receiver(s) that comply with Innovation, Science and Economic Development Canada's licence-exempt RSS(s). Operation is subject to the following two conditions: (1) This device may not cause interference. (2) This device must accept any interference, including interference that may cause undesired operation of the device.

L'émetteur/récepteur exempt de licence contenu dans le présent appareil est conforme aux CNR d'Innovation, Sciences et Développement économique Canada applicables aux appareils radio exempts de licence. L'exploitation est autorisée aux deux conditions suivantes : (1) L'appareil ne doit pas produire de brouillage; (2) L'appareil doit accepter tout brouillage radioélectrique subi, même si le brouillage est susceptible d'en compromettre le fonctionnement.

### ★RF Exposure Compliance

This equipment complies with FCC/IC radiation exposure limits set forth for an uncontrolled environment. This transmitter must not be co-located or operating in conjunction with any other antenna or transmitter.

Cet équipement est conforme aux limites d'exposition aux radiations FCC/IC établies pour un environnement non contrôlé. Cet émetteur ne doit pas être situées ou opérant conjointement avec toute autre antenne ou l'émetteur.

### ★CAN ICES-3 (B)/NMB-3(B)

Hereby, [Hanwang Technology Co., Ltd.] declares that the radio equipment type [Go Go Bird 102, FYC 102] is in compliance with Directive 2014/53/EU. The full text of the EU declaration of conformity is available at the following internet address:  
[www.http:\\www.gogobird.com](http://www.gogobird.com)

# Thanks

We hope you enjoy your purchase, thank you for being a valued customer.

Should you have any questions, feel free to contact us : [cs@hanwang.com.cn](mailto:cs@hanwang.com.cn)

Go Go Bird, YOURS TO EXPLORE THE SKY!



Go Go Bird



Go Go Bird



Go Go Bird

**RoHS**

**CE**

**FC**



Not suitable for children under three years.

**MADE IN CHINA**