

SWAN-K1

快速入门指南 V1.2 2021.1

©2021 禾启智能 版权所有

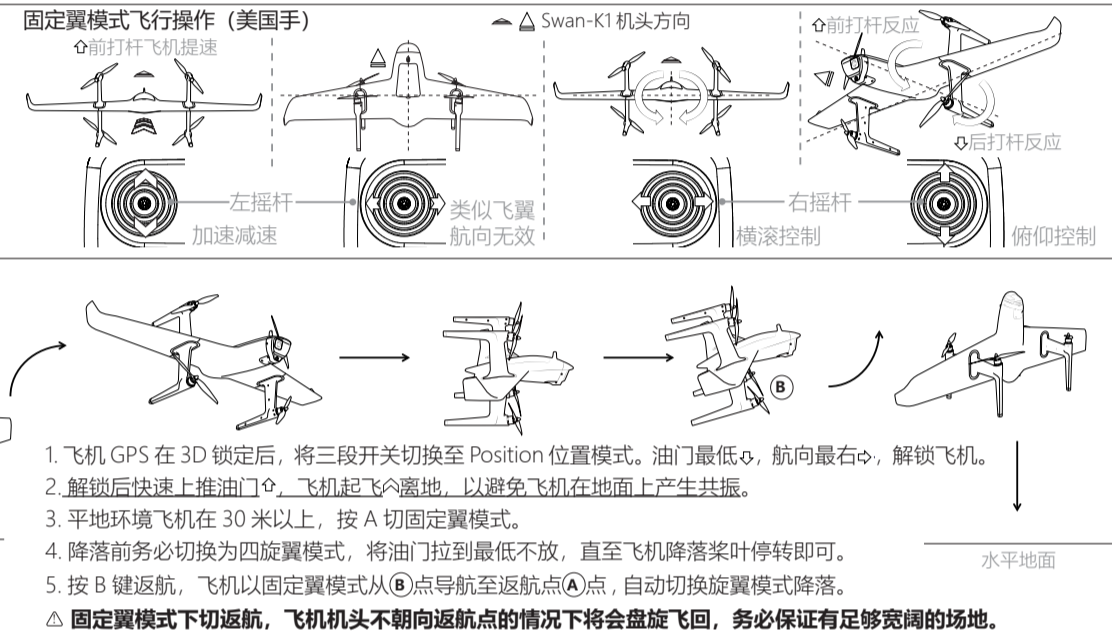
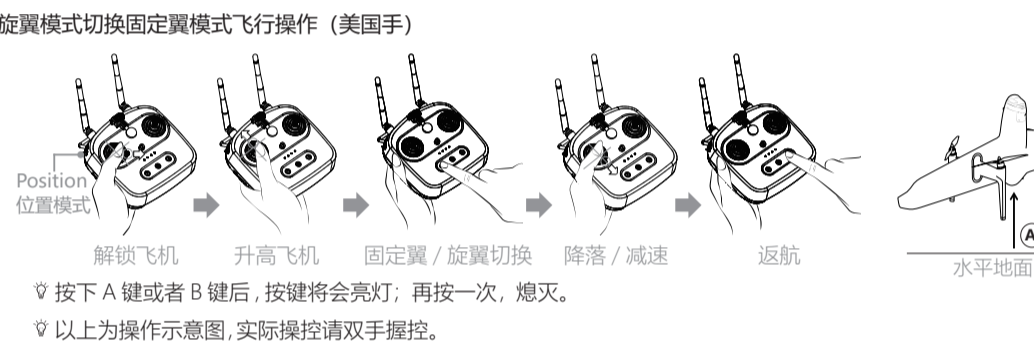
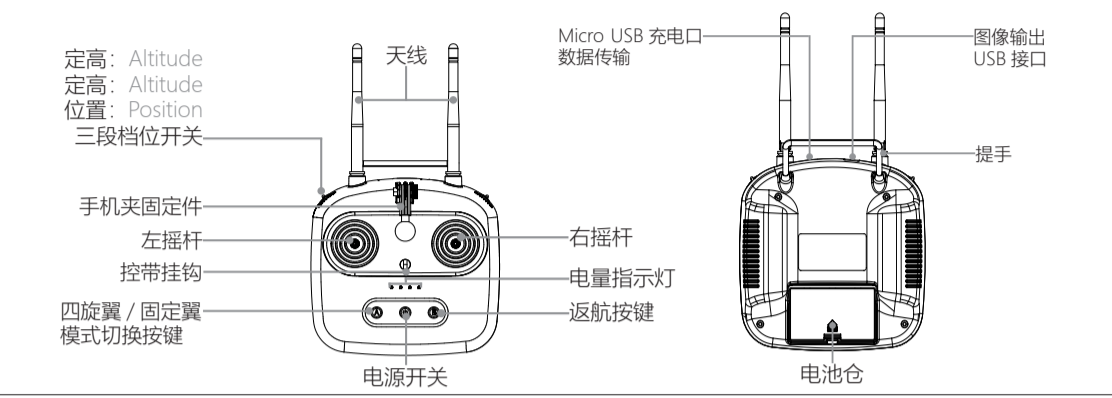
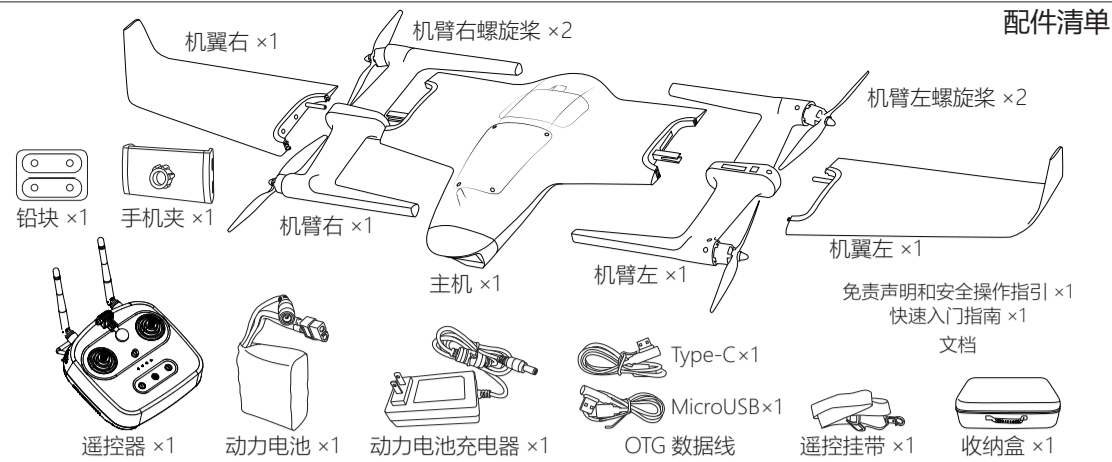
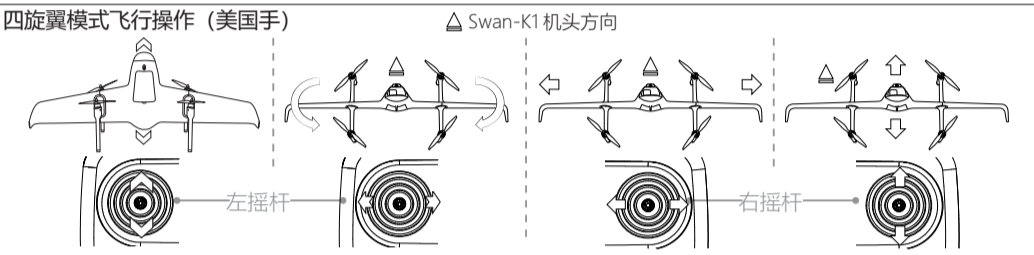
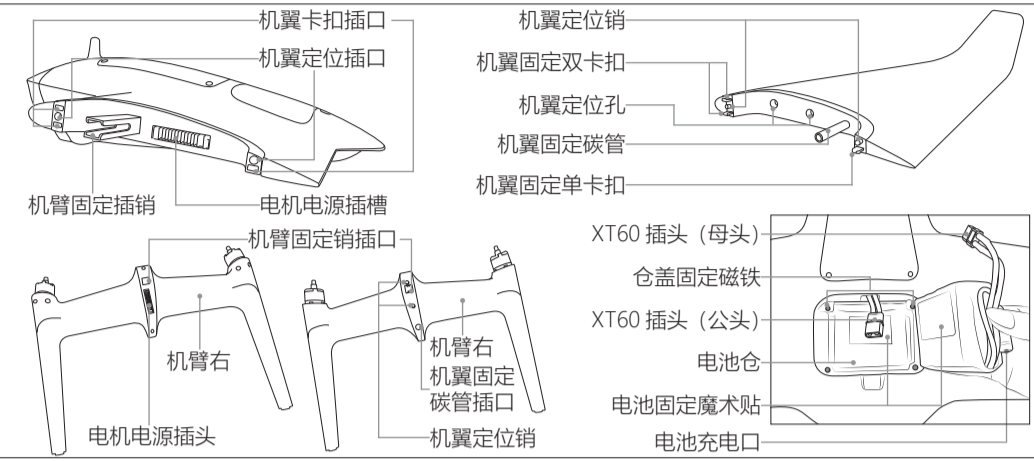
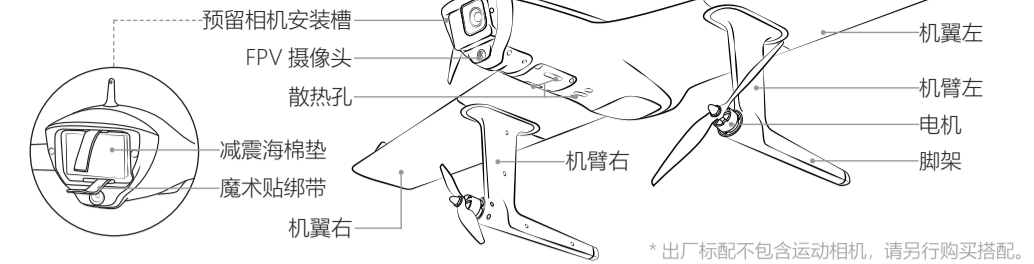

SWAN-K1 快速入门指南

©2021 禾启智能 版权所有

01 观看入门视频 / 下载 APP

观看入门教学视频:
请使用手机应用扫描二维码观看视频。
HEQ 技术支持: http://www.hequavtech.com/multi_rotor/

扫码观看视频 扫码下载 APP 官方公众号

* APP 仅支持安卓系统。
✦ 飞行前请给遥控器、动力电池进行充电。动力电池充电的具体操作详见步骤 02。
△ 根据中国民用航空局相关规定在使用本产品前, 您需在民航局官方线上系统进行实名登记。具体操作请访问: <https://uas.caac.gov.cn/>
微信扫码关注官方公众号, 了解更多产品资讯。
※ 内容如有变更, 恕不另行通知。
※ 由于产品迭代, 外观存在稍微的差异, 请以实物为准。

02 动力电池充电与保养

充电:
1. 掀开电池仓盖子。
2. 取出电池。
3. 先将充电器插入插座, 再将电池充电口插入充电器连接口。充电完成后指示灯由红变成绿色。
保养: 电池储存三个月左右, 需将电池充放电一次, 以保持电池的活性。

✦ 飞行结束后, 请将电池放置通风阴凉环境, 温度下降后再进行充电。
✦ 充电时, 务必先插充电器电源, 再插电池充电口。
✦ 充满电后请断开充电器与电池的连接, 并拔掉下电源。定期检查并保养充电器与电池, 经常检查电池外观以及线路。切勿使用损坏的充电器与电池。

03 准备遥控器

1. 将遥控器天线展开并垂直朝上。
2. 长按电源键开机, 4 个 LED 灯从左至右依次点亮, 满电时 4 个 LED 保持常亮。长按电源键关机 4 个 LED 从右至左依次熄灭。
3. 安装手机夹, 将手机固定并连接 USB。手机提示: 允许应用“HEQ FLY”访问该 USB 设备吗? 请选择“确定”。

✦ 长按开机 电量 LED 亮起 从左往右依次亮起
✦ 安装手机夹, 并连接手机 点击蓝牙图标, 选择 T10
✦ 满电情况下, 4 个 LED 指示灯常亮。
✦ 飞行前请将遥控电池电量充满。

04 飞机的安装与拆解

安装: 装左右机臂后, 安装机翼, 务必将卡扣锁紧。

① 安装右机臂 ② 安装左机臂
③ 安装机翼 ④ 锁紧下卡扣

拆解: 卸下左右机翼后, 拆机臂。

① 拆下机翼 ② 拆下机臂
③ 拆下机翼 ④ 拆下机臂

05 给飞机上电

1. 将电池仓上盖掀开, 收纳好充电头, 有魔术贴的一面朝下对准电池仓内的魔术贴固定动力电池。
2. 连接 XT60 给飞机上电。
3. 将线材收纳好, 盖好电池仓。

✦ 收纳好电池线材后, 电池仓盖可以和机身相贴合。
✦ 飞行前务必将动力电池电量充满。
✦ 起飞前请务必检查电池仓是否完全贴合机身, 以避免高速飞行时导致电池仓脱落。

06 校准磁罗盘与校准空速计

1. 校准磁罗盘: 打开 APP 进入传感器界面, 点击磁罗盘, 按步骤校准; 先按图放置飞机, 然后逆时针旋转飞机。
2. 校准空速计: 先捂住空速计进气口, 提示“请对准空速计进气口轻轻吹气”后, 对着空速计轻轻吹气。

✦ 进入磁罗盘校准 ① 按图放置飞机
✦ ② 按图示操作直至已完成 进入空速校准
✦ ① 按图校准 ② 校准完成

07 安装运动相机 (选装)

为了给客户极致的固定翼航拍体验, 机头预留约 68mm×50mm 运动相机安装槽, 可拓展加装以获得最佳的飞行视频。如果不安装运动相机, 请捆绑配重铅块以获得更稳定的 FPV 飞行体验。

✦ 将相机放置在飞机预留的相机安装槽内。
✦ 将魔术贴绑带捆绑好运动相机。
✦ 飞行前按下录像键, 即可拍摄固定翼飞行影像。

✦ 放置运动相机 / 配重铅块 捆绑运动相机
✦ 为保证飞机快速获得 GPS 进入 3D 锁定状态, 建议在遥控器能切换 Position 档位情况下再安装相机。
✦ 可以支持 Gopro 5、6、7、8; DJI Action。
✦ 机头部分需要铅块配重 (最高负重重量 120g 左右)
* 出厂标配不包含运动相机, 如有需要请另行购买搭配。

08 安装螺旋桨

1. 螺旋桨分顺时针 / 逆时针旋转, 安装时留意桨叶标识进行区分: 黑螺帽为顺时针, 白螺帽为逆时针。
2. 顺时针旋转的螺旋桨逆时针旋转进行固定; 逆时针旋转的螺旋桨顺时针固定。起飞前确保已拧紧桨叶。

✦ 黑螺帽螺旋桨 白螺帽螺旋桨
✦ 白螺帽螺旋桨 黑螺帽螺旋桨
✦ 顺时针拧紧。 逆时针拧紧。
✦ 请严格按图安装螺旋桨, 起飞前务必确认已经拧紧。
✦ 请勿新旧螺旋桨混用。
✦ 起飞 / 降落时请远离人群。
✦ 禁止触摸高速旋转中的螺旋桨, 否则可能受到螺旋桨严重的伤害。
✦ 请使用官方原装螺旋桨, 使用副厂螺旋桨导致的损坏, 厂家概不负责。

SWAN-K1

Quick start guide V1.2 | 2021.1

©2021 HEQ Intelligent All rights reserved

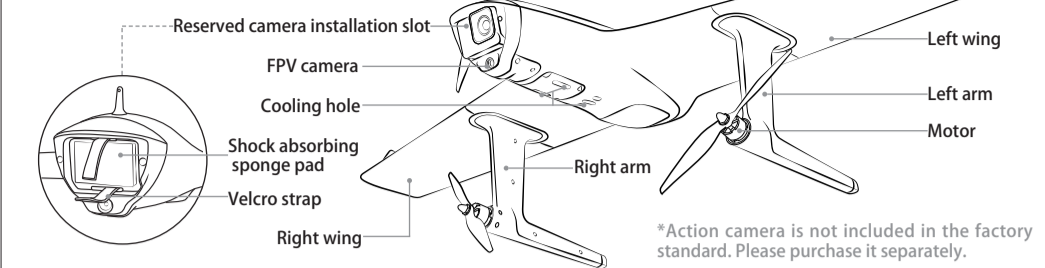

*Action camera is not included in the factory standard. Please purchase it separately.

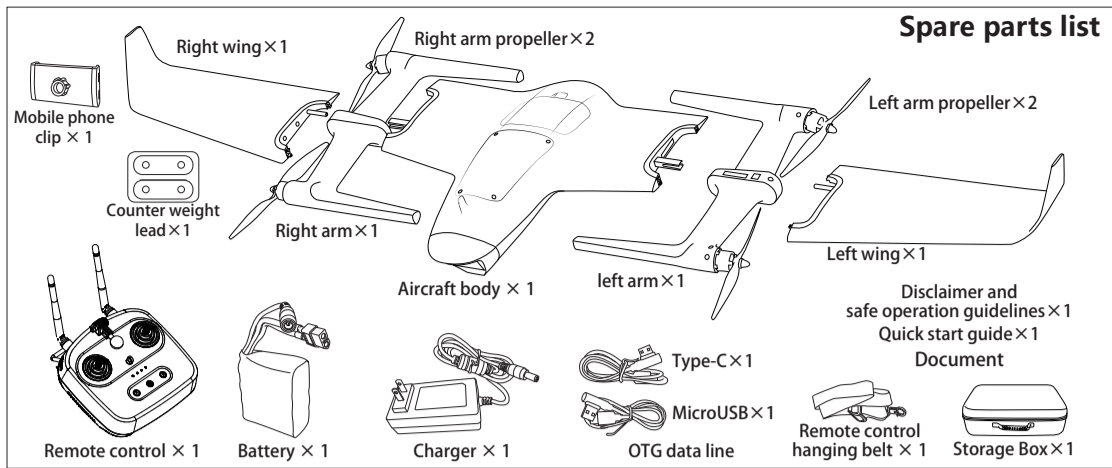
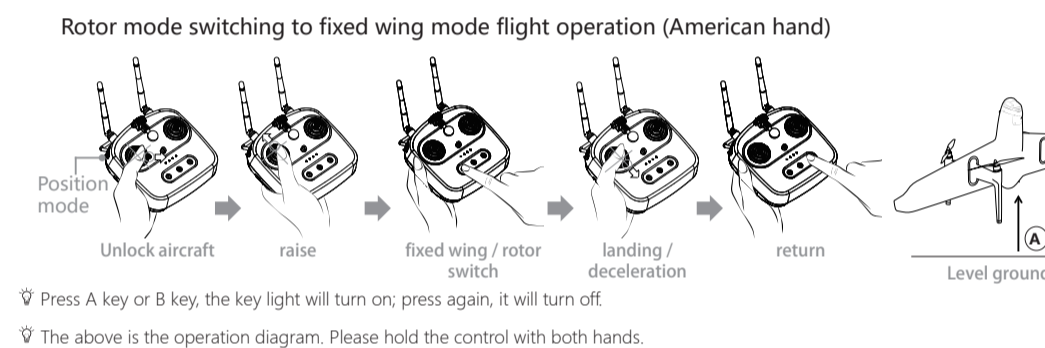
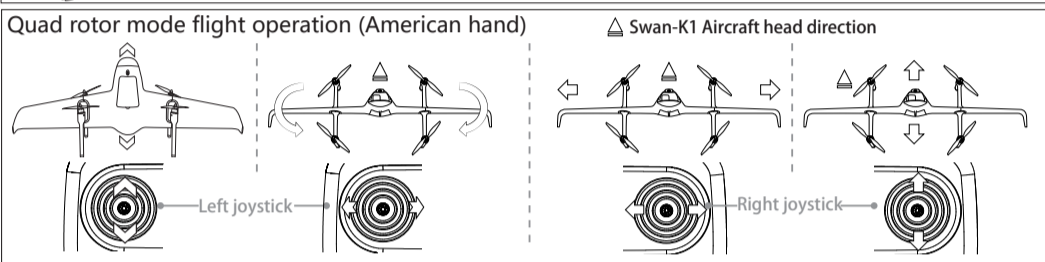
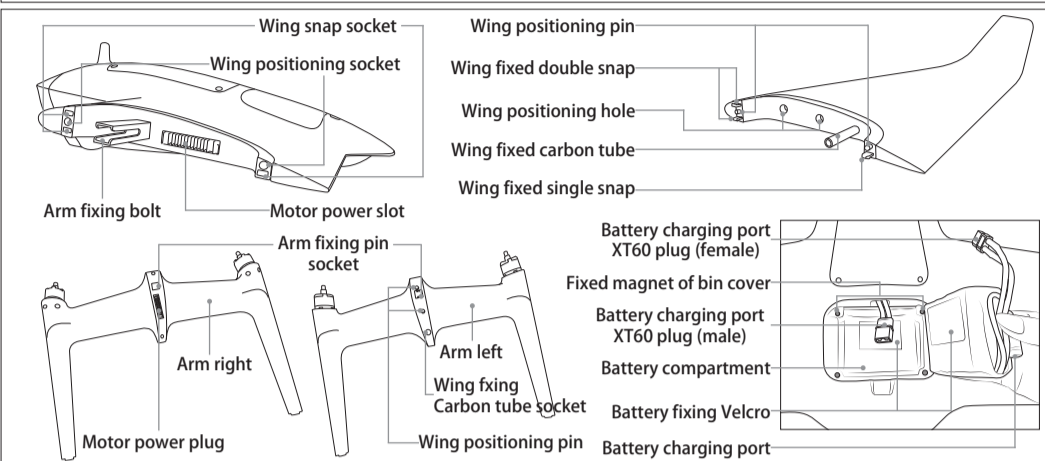

Spare parts list

Disclaimer and safe operation guidelines x 1
Quick start guide x 1
Document

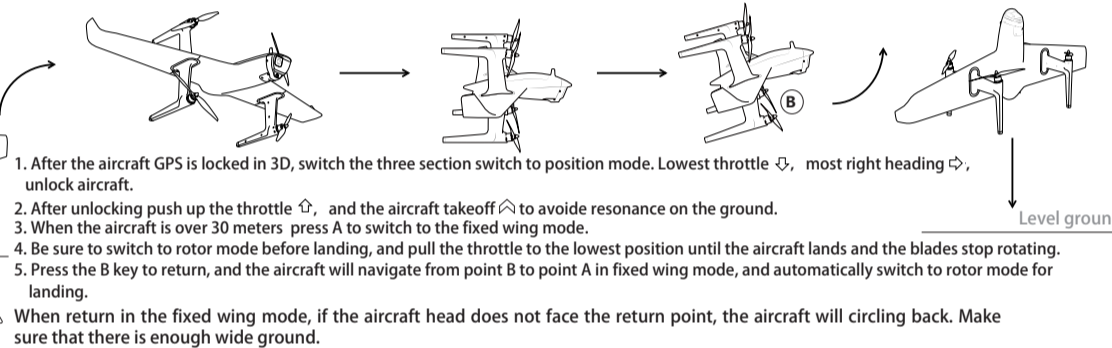
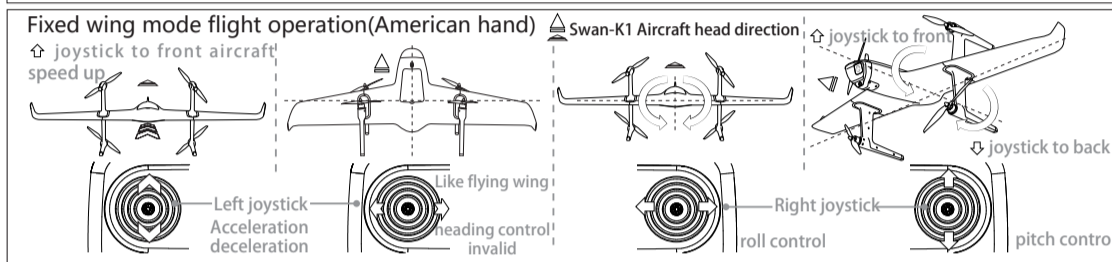
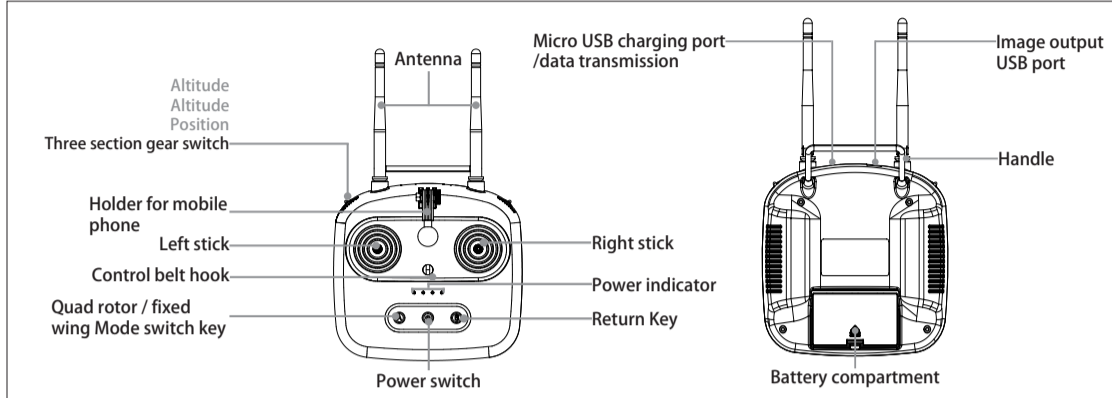

SWAN-K1 Quick start guide

©2021 HEQ Intelligent All rights reserved

01 Watch the teaching video / download APP

Watch the entry teaching video. Please use the mobile app to scan the QR code to watch the video. HEQ Technical support: http://www.hequavtech.com/multi_rotor/

Scan QR code to watch video | Scan QR code to download app | Official account

*App only supports Android system.

Please charge the remote control and power battery before flying. Please refer to step 02 for specific operation of power battery charging.

The regulations vary from country to country. Please verify your real name according to the regulations of your country/region.

Please scan the WeChat QR code to pay attention to the official account, and knows more product information from it.

The contents are subject to change without prior notice.

Due to product iteration, there are slight differences in appearance. Please refer to the actual product.

02 Battery charging and maintenance

Charging:

- Pull out the battery compartment cover.
- Take out the battery.
- Plug the charger into the socket first, and then insert the battery charging port into the charger connection port. After charging done, the indicator light changes from red to green.

Attention: the battery should be charged and discharged once for about three months to keep the battery active.

Insert AC socket | Connect the charging port | Charging indicator | Battery | Charger | Charging port

Pull out the upper cover and take out the battery

After the flight, please place the battery in a cool and ventilated environment, and recharge it after the temperature drops.

When charging, be sure to plug in the charger first and then the battery charging port.

After fully charged, please disconnect the charger from the battery and unplug the power supply. Check and maintain the charger and battery regularly. Check the appearance and circuit of the battery regularly. Do not use damaged chargers and batteries.

03 Remote control

- Unfold the remote control antenna and point it vertically upward.
- Press and hold the power Key, and the four LEDs will be on from left to right in turn, and they will remain on when the power is full. Press and hold the power button to turn off. The 4 LEDs turn off from right to left.
- Install the mobile phone clip, fix the mobile phone and connect it to USB. Mobile indicate: Allow application "HEQ FLY" to access the USB device? Please select "OK".

Press and hold the power on key, the leds will be turned on from left to right.

Install the mobile phone clip and Click the Bluetooth icon to connect the mobile phone. Select T10.

When fully charged, 4 LED indicators are always on.

Please charge the remote control battery fully before flying.

04 Installation and disassemble of aircraft

Installation: after installing the left and right arm, install the wing, and be sure to lock the clasp.

Disassemble: after removing the left and right wings, dismantle the arm.

05 Power up the aircraft

- Pull out the upper cover of the battery compartment, store the charging head, and align the side down with the Velcro in the battery compartment to fix the power battery.
- Connect XT60 to power up the aircraft.
- Store the wire and cover the battery compartment well.

Pull out the cover | Place the battery | Connect XT60 | Wire storage | Storage effect | Cover installation

After storing the battery wire, the battery compartment cover can fit with the body.

Make sure the power battery is fully charged before flying.

Before take-off, please check whether the battery compartment is fully fitted with the body to avoid falling off during high-speed flight.

06 Calibration of magnetic compass and airspeed meter

- Calibrate Magnetic Compass: open app to enter sensor interface, click magnetic compass and calibrate step by step; first place the aircraft according to the figure, and then rotate the aircraft anticlockwise.
- Calibrate the airspeed meter: cover the air inlet of the airspeed meter first, and then gently blow the air into the airspeed meter after the prompt "please blow gently aim at the air inlet of the airspeed meter".

Magnetic compass calibration | Airspeed meter calibration

1. Place the aircraft according to the diagram. | 2. Operating follow the diagram until it is finished

1. Calibration according to the diagram | 2. the calibration is completed

07 Installation of action Camera (optional)

In order to give customers the ultimate experience of fixed wing aerial photography, a 68mm x 50mm mobile camera installation slot is reserved in the head, which can be expanded to obtain better flight video. If you do not install a action camera, please tie the weight lead to get a more stable FPV flight experience.

- Place the camera in the slot reserved for the camera.
- Tie the Velcro strap to the action camera.
- Press the video key before flying.

Placing action camera/Counter weight lead | binding action Camera

In order to ensure that the aircraft can quickly get GPS and then into 3D lock state, it is recommended that you install the camera when the aircraft can be switched to position mode.

It can support GoPro 5, 6, 7, 8; DJI action.

The head part needs lead counterweight (the maximum load weight is about 120g).

*Action camera is not included in the factory standard. If necessary, please purchase it separately.

08 Installation of propeller

- The propeller rotates clockwise / anticlockwise. Pay attention to the blade identification during installation: the black nut is clockwise, and the white nut is counterclockwise.
- The propeller with clockwise rotation is fixed by anticlockwise rotation; the propeller with counter clockwise rotation is fixed by clockwise. Make sure the blades are tightened before takeoff.

Black nut propeller | White nut propeller | White nut propeller | Black nut propeller

Tighten clockwise. | Tighten counterclockwise.

Please install the propeller in strict accordance with the diagram and make sure it is tightened before taking off.

Do not use old and new propellers together at the same time.

Keep away from the crowd when taking off / landing.

Do not touch the high-speed rotating propeller, or you may be seriously injured by the propeller.

Please use the official original propeller. The manufacturer will not be responsible for the damage caused by the use of the auxiliary propeller.