



机身组装
Assemble the Fuselage

1 对齐 Align
 C1, C2粘在一起, 按预留孔对齐
 Paste together the C1 and C2, and align with reserved holes

2 翻转 Turn over
 C1-1L粘贴时按预留孔对齐
 Align with the reserved holes when paste the C1-1L

3 翻转 Turn over
 C1-1L / C1-1R

4 把侧板粘贴到步骤3拼装的骨架上, 如下图。
 Paste the side panel onto the skeleton of step 3 as shown below

仓身盖为可开合设计, 请勿用胶水粘死到机身上。
 The cover is detachable. Do not stick to the body with glue.

5 3X4mm桐木 Paulownia

6 3X3mm轻木 Balsawood
 此处按实际长度截取
 Cut here by actual length

7 M2

8 3X3mm轻木 Balsawood
 安装圆木杆
 install the round wooden rods.

9 M1
 粘贴蒙版M1时, 用水稍加湿润, 方便弯曲, 然后进行粘贴。
 When pasting the covering mask M1, it is slightly moistened with water, which is easy to bend and then pasted.

10 磁铁 magnet
 仓身内舵机位置
 servo position inside the cabin
 机身与仓身盖两部分磁铁为相吸状态
 The two parts of the fuselage and the body cover are in a state of attraction.

11 U
 Fx2

12 L
 R

机翼, 尾翼组装
Assemble the Wing and Tail

尾翼组装
Assemble the Tail

13 R15, R11, R12, R23, R1, R7, R5, R8, R3, R14, R19, R13, R16, R20, R17, R22, R21, R24, R10, R9, R4, R2

14 14.1, 14.2
 E1, E12, E11, E13, E2, E3, E7, E19, E10, E22, E6, E18, E9, E14, E21, E5, E17, E8, E20, E4, E23, E15, E16

机翼组装
Assemble the Wing

15 W7, W6, W5, W4, W3, W2, W1-1, W1, L1

16 3X3mm轻木 Balsawood
 此处按实际长度截取
 Cut here by actual length

17 顶面 Top
 M4

按实际形状裁剪PVC座舱罩, 然后粘贴到舱盖上。
 Cut the PVC canopy cover according to the actual shape and then paste it onto the hatch cover.

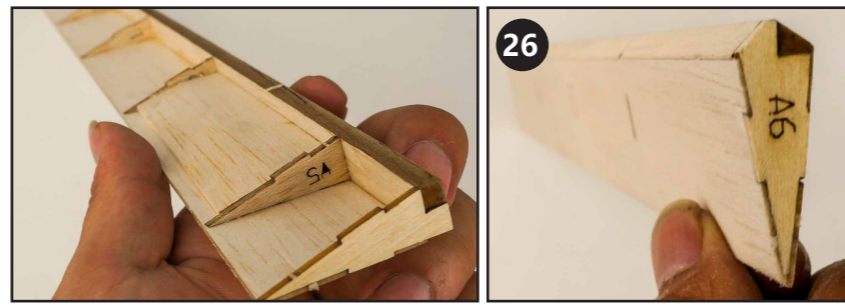
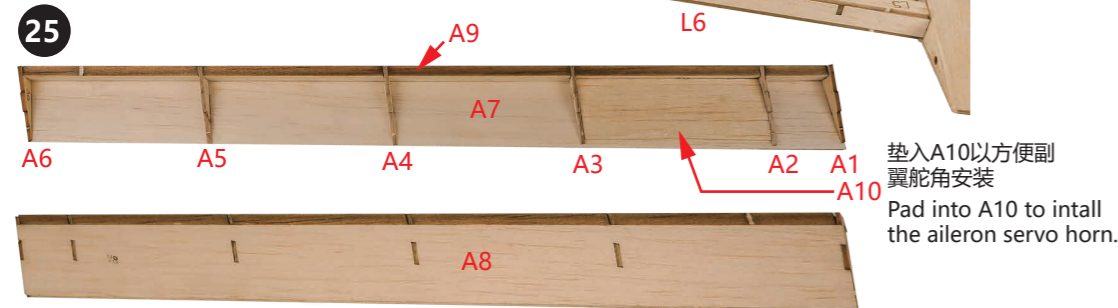
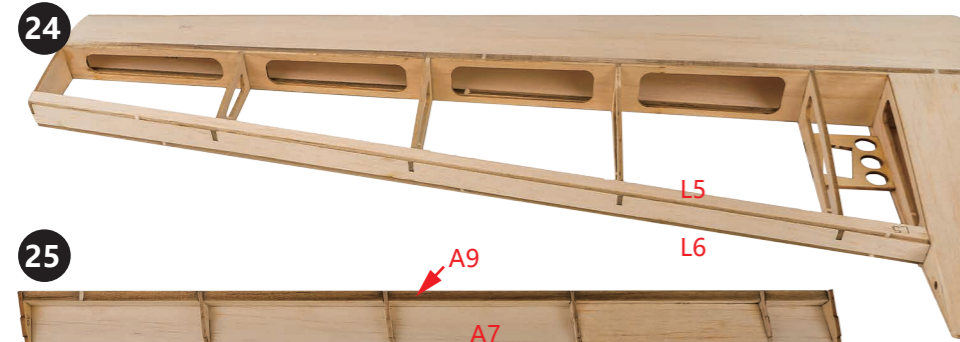
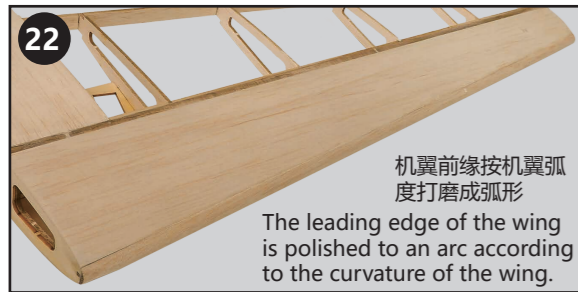
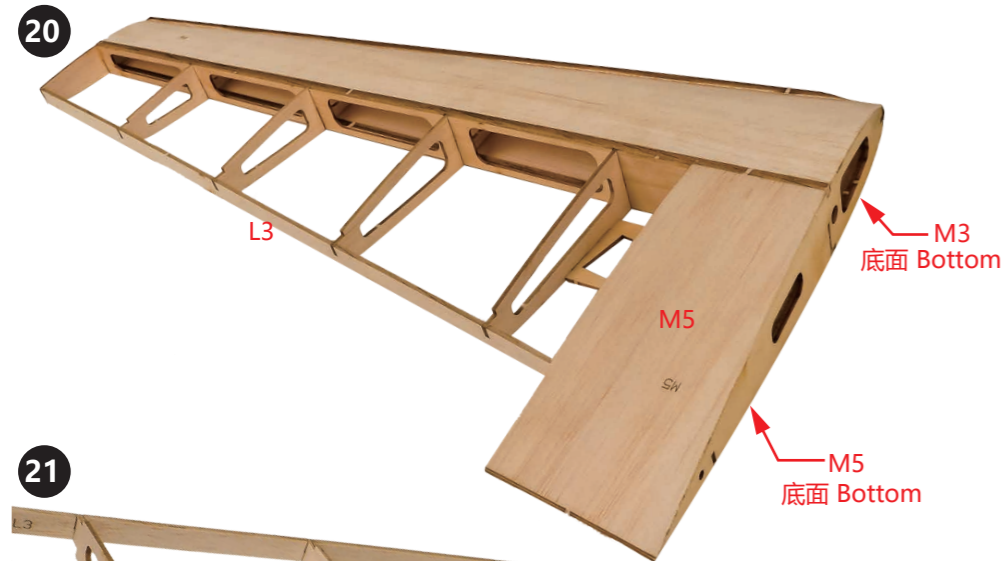

**各部件组装
Components Assembly**

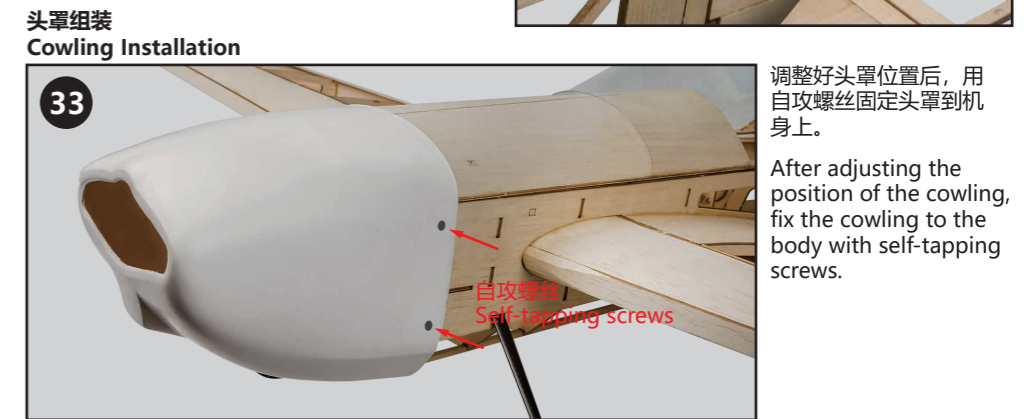
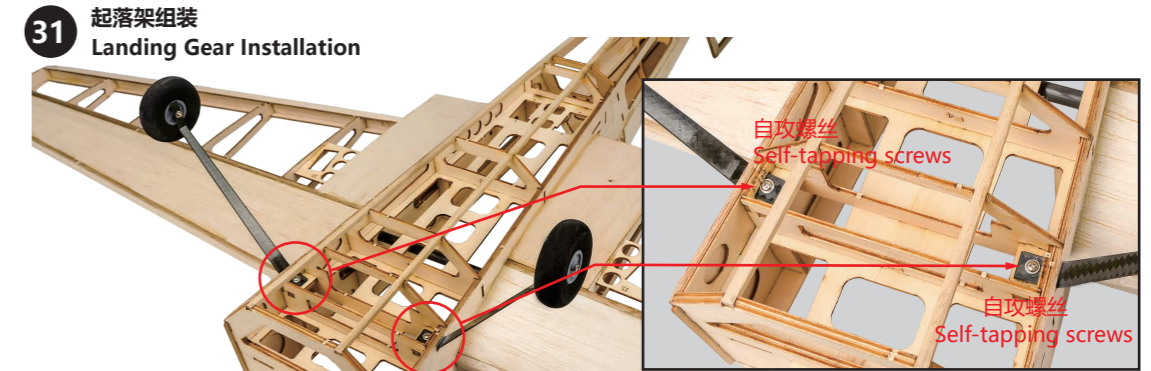
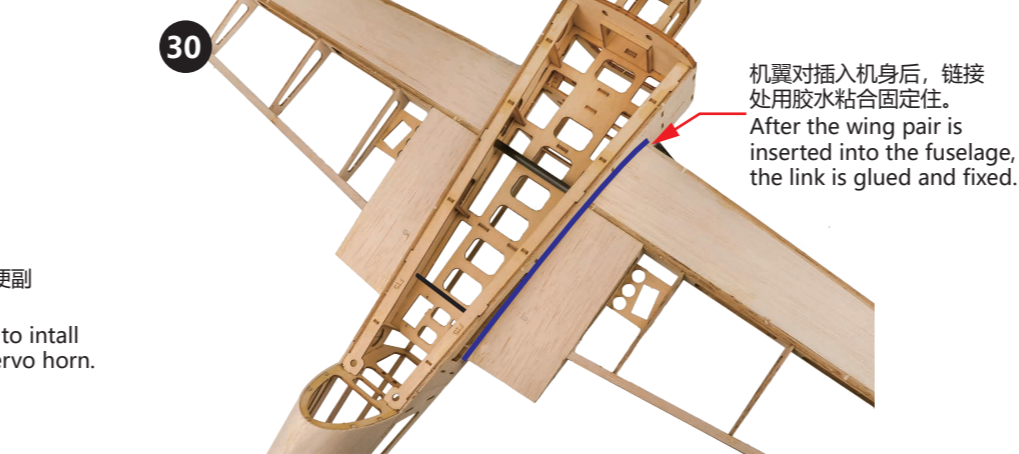
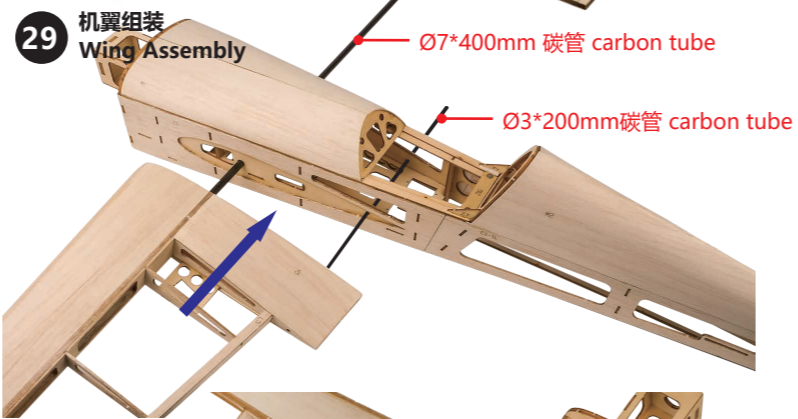

**起飞重心设置
C.G. Setting**

调整好重心后即可进行试飞
After adjusting the center of gravity, you can test flight.

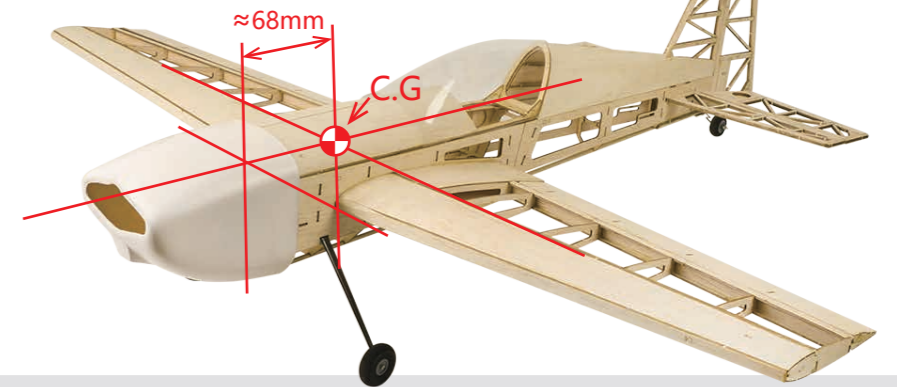

参数	推荐配置	Suggested Equipment
翼展: 1000mm	马达: 2212-2216 900-1200KV	Motor: 2212-2216 900-1200KV
机长: 900mm	电调: 20-30A	ESC: 20-30A
起飞重量≈800g	桨叶: 9-11寸	Propeller: 9-11 inch
Specification	舵机: 9g*4	Servos: 9g*4
Wingspan: 1000mm	电池: 3s 1500-2200mAh	Battery: 3s 1500-2200mAh
Length: 900mm	通道≥4CH	Radio≥4CH
Flying Weight≈800g		