

QX-MOTOR 70MM EDF(12) Outer-Rotor Brushless Motor QF2827 Instruction Manual

性能资料:

电机型号 (model)	QF2827
K V (rpm)	2600KV/1800KV
架构 (Configu-ration)	9N6P
轴直径 (Shaft Diameter)	4.0mm
马达直径 (motor Diameter)	28mm
重量 (weight(g))	175G
锂电指数 (No. f cells)	6S Lipo
最大连续功率(W) (max continuous power)/10S	1500W
最大连续电流(A) (max continuous current)/10S	65A

Prop (桨)	Volts (V) 电压	Amps (A) 电流	Watts (W) 输出功率	Thrust (g) 推力	Thrust (oz)	Efficiency (g/W) 力效	Efficiency (oz/W)	Throttle油 门	Motor model 马达型号	ESC 电调
70mm EDF (12叶)	16	62.0	992	1800	63.49	1.81	0.06	100%	QF2827-2600KV	80A
	25	37.0	925	1927	67.97	2.08	0.07	100%	QF2827-1800KV	60A

外形尺寸图:

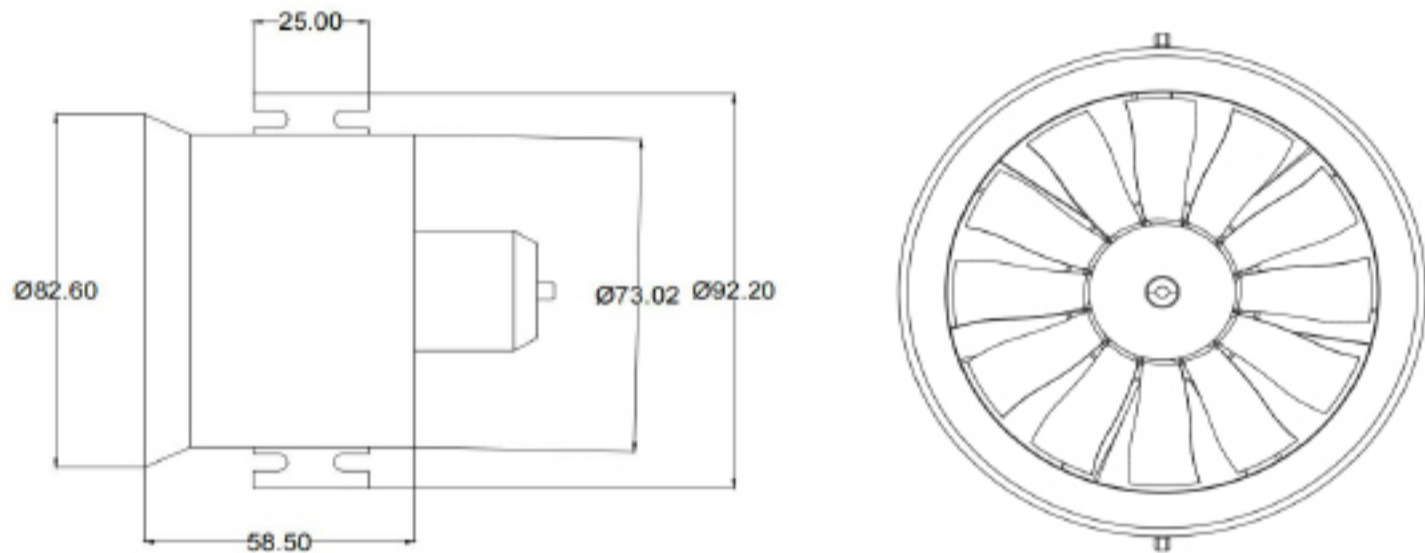

接线方法:

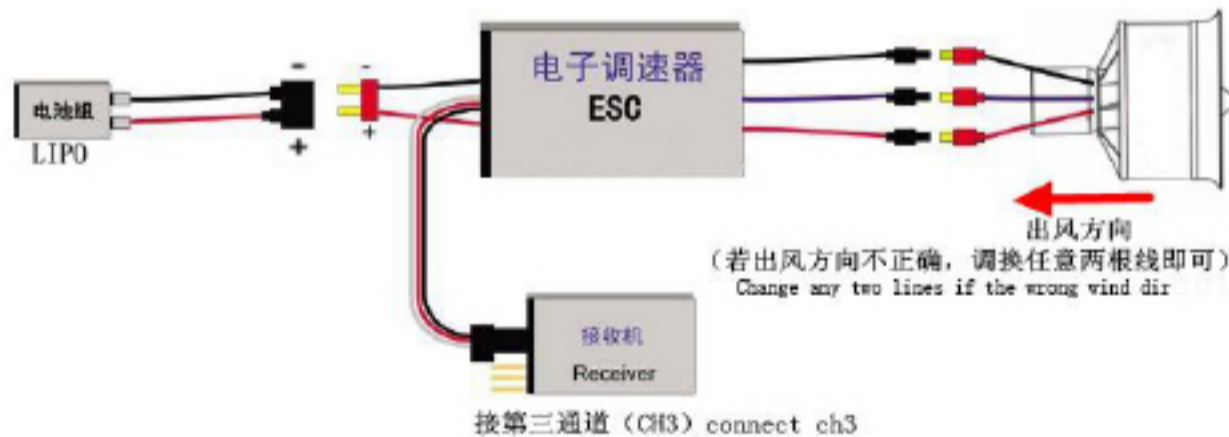

注意事项:

- 选择使用本产品, 表明你知晓并遵守安全操作条款。否则停止使用本产品。
By choosing to use this product, you are aware of and comply with the safe operating conditions. Otherwise stop using this product.
- 为了安全请勿将进风品或者出风口朝向自己或者他人。
For safety, do not point the air intake or outlet to yourself or others.
- 使用本产品应在厂家指导的参数设置下进行安装使用, 不可更改电压、超负荷或其他改装行为。
The use of this product should be installed and used under the parameter setting specified by the manufacturer. The voltage, overload or other modification behavior cannot be changed.
- 本产品出厂时已经做过“动平衡”调试。请勿自行拆卸, 改装, 否则影响产品平衡。
This product has been "dynamically balanced" debugging at the factory. Do not disassemble or modify it yourself, otherwise it will affect the product balance.
- 产品动平衡调试时, 管道内壁会有少许划痕, 不能接受者请不要购买。
When the product is dynamically balanced, there will be a little scratch on the inner wall of the pipe. If you cannot accept it. please do not buy it.