

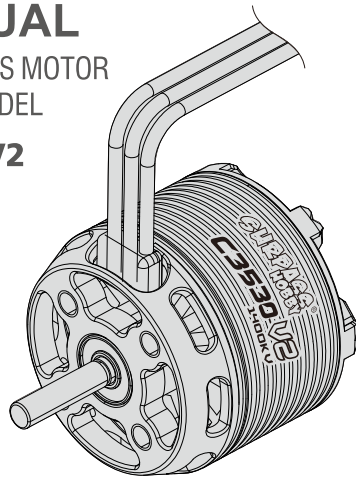

USER MANUAL

OUTRUNNER BRUSHLESS MOTOR
FOR AIRCRAFT MODEL

C35 SERIES V2



Thank you for purchasing Surpasshobby product, this is a powerful RC hobby product rather than a toy. It must be operated with care and common sense of safety. Any wrong operation may cause personal injury or damage the product. This product does not allow children to use it without the direct supervision of an adult. Before installation and use, please read and follow the operating procedures specified in this manual. We do not assume any liability arising from the use of this product, including but not limited to compensation for incidental or indirect loss; at the same time, we do not assume any liability arising from unauthorized modifications to the product.

WARNINGS

- Before using, Ensure that the power system is reasonable. Unreasonable power matching will cause the motor to be damaged due to overload.
- Do not over tighten the screws when installing the motor. Be sure to use the appropriate mounting screws.
- Before connecting the motor, Ensure that The insulated parts are well treated, Short circuit will destroy the product.
- Be sure to connect the components correctly. Wrongly connected may not work properly, or the components may be damaged or other unpredictable conditions.
- Avoid the motor operating temperature exceeding 100°C (212°F). High temperature may cause the rotor to demagnetize and damage motor
- Do not touch the motor after use to avoid overheating and scalding. Wait for the motor to cool down completely before using it.
- Precision balanced rotor, smoothness for best reliability and maximum RPM.
- High Purity Copper Windings Maximizes Efficiency.
- Precision Engineered for Maximum Energy Conversion.

FEATURES

- 14 Pole Hi-torque rotor design, stable output power.
- Fits all fixed wing aircraft model.
- CNC Machined 6061 T6 aluminum front and rear cover.

INSTALLATION AND CONNECTION

1. Install the motor

The motor mounting screws are M2.5/M3 screw holes.

2. Motor connection

There is no polarity on the #A/#B/#C three ESC-to-motor wires, so do not worry about how you connect them initially. You may find it necessary to swap two wires if the motor runs in reverse.

3. Inspection

Before turning on the power of the remote control, please Ensure double check the correctness of the motor connection and the reliability of the installation.

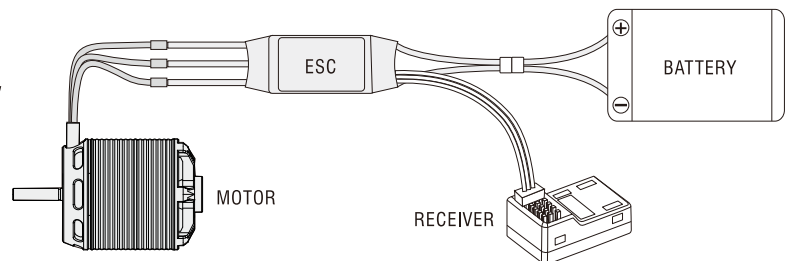

SPECIFICATIONS

Model	Item Number	KV (RPM/Volt)	MAX Watts (W)	Voltage Range(V)	Max Current (A)	Rotor Poles	No load Current(A)	Resistance (Ω)	Motor Size (mm)	Stator Size (mm)	Weight (g)	Propeller (Inch)
C3530-V2	SP-235300-01	1700	420	7~15	42	14	1.8	0.041	Ø35x28.5	Ø28x08	78	7x4/6x6
C3536-V2		1400	350	7~15	35	14	1.2	0.059	Ø35x28.5	Ø28x08	78	9x4.5/8x4/7x7
C3530-V2		1100	310	7~15	30	14	0.7	0.113	Ø35x28.5	Ø28x08	78	9x5/10x4.7
C3536-V2	SP-235360-01	1500	750	7~15	55	14	2.5	0.025	Ø35x34.5	Ø28x14	109	8x4/9x6/10x6
C3536-V2		1300	680	7~15	50	14	1.8	0.038	Ø35x34.5	Ø28x14	109	9x4.5/10x4.7/9x5
C3536-V2		1050	500	7~15	38	14	1.5	0.055	Ø35x34.5	Ø28x14	109	9.5x5/10x6/11x5
C3536-V2		910	400	7~15	30	14	1.2	0.072	Ø35x34.5	Ø28x14	109	10x7/11x8.5/12x5
C3542-V2	SP-235420-01	1450	1050	7~15	78	14	2.3	0.021	Ø35x40.5	Ø28x20	132	12x5/11x7/13x8
C3542-V2		1250	850	7~15	65	14	2.1	0.026	Ø35x40.5	Ø28x20	132	8x7/9x5/10x4
C3542-V2		1000	750	7~15	55	14	2	0.039	Ø35x40.5	Ø28x20	132	10x6/12x6.5/13x8
C3548-V2	SP-235480-01	1100	1100	7~15	72	14	2.6	0.028	Ø35x46.5	Ø28x26	172	12x6/12x6.5/13x8
C3548-V2		900	1000	7~18	60	14	2.2	0.033	Ø35x46.5	Ø28x26	172	11x8/13x6/14x7
C3548-V2		790	840	10~20	50	14	2	0.051	Ø35x46.5	Ø28x26	172	12x7/13x7/14x7

C3530-V2/C3536-V2/C3542-V2/3548-V2

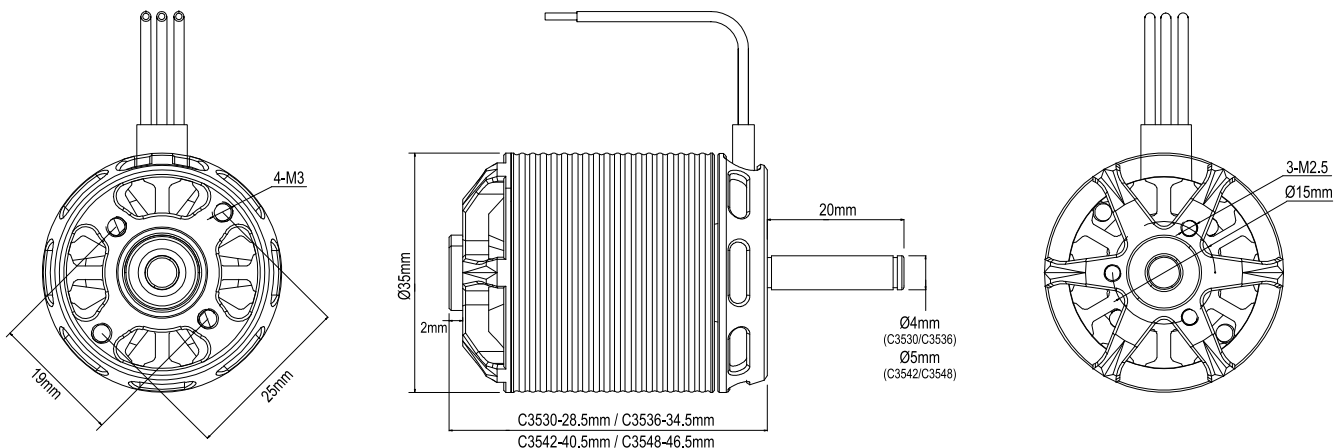



使用说明书

固定翼 外转无刷电机 C35 SERIES V2

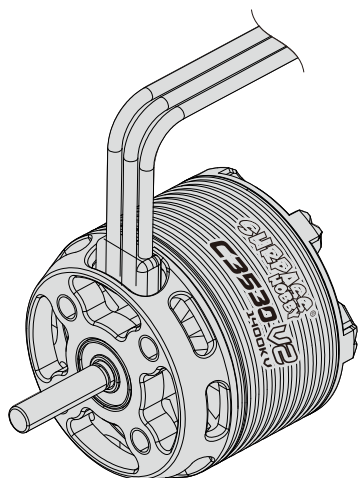

感谢您购买本产品，这是一个动力模型产品而不是玩具。它必须谨慎操作和具备安全常识，任何错误操作可能会导致人身伤害或损坏产品。本产品不允许儿童在没有成人直接监督的情况下使用。在安装和使用前，请务必阅读并遵守本手册规定的操作程序。我们不承担因不当使用本产品而引起的任何责任，包括但不限于对附带损失或间接损失的赔偿责任；同时，我们不承担因擅自对产品进行修改所引起的任何责任。

注意事项

- 使用此电机前，请确保动力搭配合理，不合理的动力搭配会导致电机超载而损坏。
- 电机安装时螺丝不要过紧，务必使用尺寸合适的电机安装螺丝。
- 连接电机前，请确保需要绝缘的部位处理良好，短路会损坏产品。
- 请务必正确连接好各部件，错误连接遥控模型可能无法正常工作，或出现部件损坏和其他不可预知的情况。
- 避免电机工作温度超过130°C (266°F)，高温可能导致转子退磁并对电机造成损坏。
- 使用后切勿触摸电机，以免过热烫伤，待电机完全冷却后再使用。

产品特点

- 14极转子设计，具有强大扭力及稳定的输出功率。
- 适用于所有固定翼飞机型号。
- 数控加工6061 T6铝材前、后盖。

- 精密平衡转子，极佳平滑度和可靠性。
- 高纯度铜绕组最大限度地提高效率。
- 精密工程最大的能量转换。

安装和连接

1、安装电机

该电机安装螺丝孔径为M2.5或M3螺丝，具体安装情况可根据模型固定架而定。

2、电机连接

电机与电调连接没有严格的线序要求，电机的#A/#B/#C可以与电调的三线随意对接，若出现转向相反，任意交换两条电机线即可。

3、检查

开启遥控车电源前，请务必再次仔细检查动力系统连接的正确性及安装的可靠性。

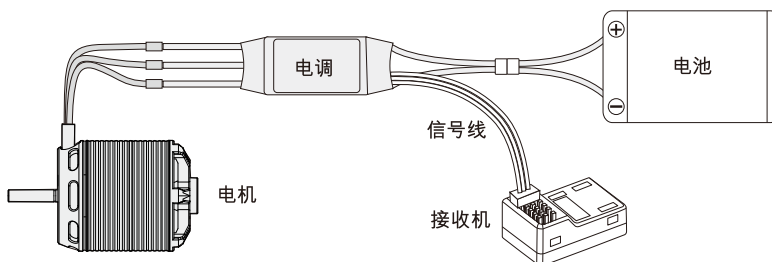

产品参数

产品型号	产品编码	KV值 (空载)	最大功率 (W)	电压范围 (V)	最大电流 (A)	电机 极数	空载电流 (A)	内阻 (Ω)	电机尺寸 (mm)	定子尺寸 (mm)	净重 (g)	螺旋桨 (英寸)
C3530-V2	SP-235300-01	1700	420	7~15	42	14	1.8	0.041	Ø35x28.5	Ø28x08	78	7x4/6x6
C3530-V2		1400	350	7~15	35	14	1.2	0.059	Ø35x28.5	Ø28x08	78	9x4.5/8x4/7x7
C3530-V2		1100	310	7~15	30	14	0.7	0.113	Ø35x28.5	Ø28x08	78	9x5/10x4.7
C3536-V2	SP-235360-01	1500	750	7~15	55	14	2.5	0.025	Ø35x34.5	Ø28x14	109	8x4/9x6/10x6
C3536-V2		1300	680	7~15	50	14	1.8	0.038	Ø35x34.5	Ø28x14	109	9x4.5/10x4.7/9x5
C3536-V2		1050	500	7~15	38	14	1.5	0.055	Ø35x34.5	Ø28x14	109	9.5x5/10x6/11x5
C3536-V2		910	400	7~15	30	14	1.2	0.072	Ø35x34.5	Ø28x14	109	10x7/11x8.5/12x5
C3542-V2	SP-235420-01	1450	1050	7~15	78	14	2.3	0.021	Ø35x40.5	Ø28x20	132	12x5/11x7/13x8
C3542-V2		1250	850	7~15	65	14	2.1	0.026	Ø35x40.5	Ø28x20	132	8x7/9x5/10x4
C3542-V2		1000	750	7~15	55	14	2	0.039	Ø35x40.5	Ø28x20	132	10x6/12x6.5/13x8
C3548-V2	SP-235480-01	1100	1100	7~15	72	14	2.6	0.028	Ø35x46.5	Ø28x26	172	12x6/12x6.5/13x8
C3548-V2		900	1000	7~18	60	14	2.2	0.033	Ø35x46.5	Ø28x26	172	11x8/13x6/14x7
C3548-V2		790	840	10~20	50	14	2	0.051	Ø35x46.5	Ø28x26	172	12x7/13x7/14x7

C3530-V2/C3536-V2/C3542-V2/3548-V2

