

## 产品规格 Product specifications

工作电压: 4.5-6V	Working voltage : 4.5-6V
响应频率: 100Hz	Response frequency : 100Hz
工作温度: 0-50°C	Working temperature : 0-50°C
尺寸: 43*28*15	Size : 43*28*15mm
重量: 11g	Weight: 11g



## 首次使用注意事项 Notice in first use

- 舵机使用中带来的压降可能会影响飞控的稳定，请注意保证稳定的工作电压。  
The voltage drop caused by the use of the servo may affect the stability of flight control. Please pay attention to ensure a stable working voltage.
- 三角翼/V尾机型请先关闭遥控器内部混控。  
For Delta wing/V-tail models, please turn off the internal mixing control of the remote control firstly.
- 若在飞行中调整了微调，请在降落后进行断电重启或中立点校准。  
If micro adjustments are made during flight, please perform power off and restart or neutral point calibration after landing.

## 设备安装&线路连接 Equipment installation & line connection

### 设备安装 Equipment installation

- 正常安装固定翼电子设备并调试好。  
Install and debug the fixed wing electronic equipments normally.
- 将飞控设备长边与机身平行，标签面超上，尽量靠近重心和中心线处粘牢。  
Place the long side of the flight control device parallel to the fuselage, the label surface upwards, and as close to the center of gravity as possible and glue firmly at the center line.

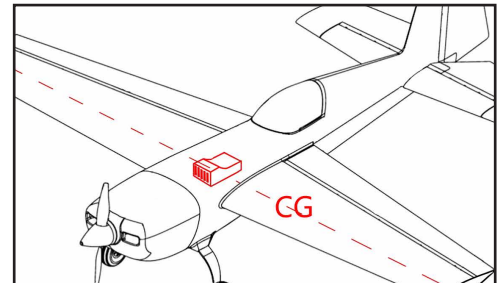

### 线路链接 (不同接收机的通道定义不同，请注意。)

### Line connection (Channel definitions vary for different receivers, please note.)

- 副翼Y线模式  
Aileron y-Y-line pattern

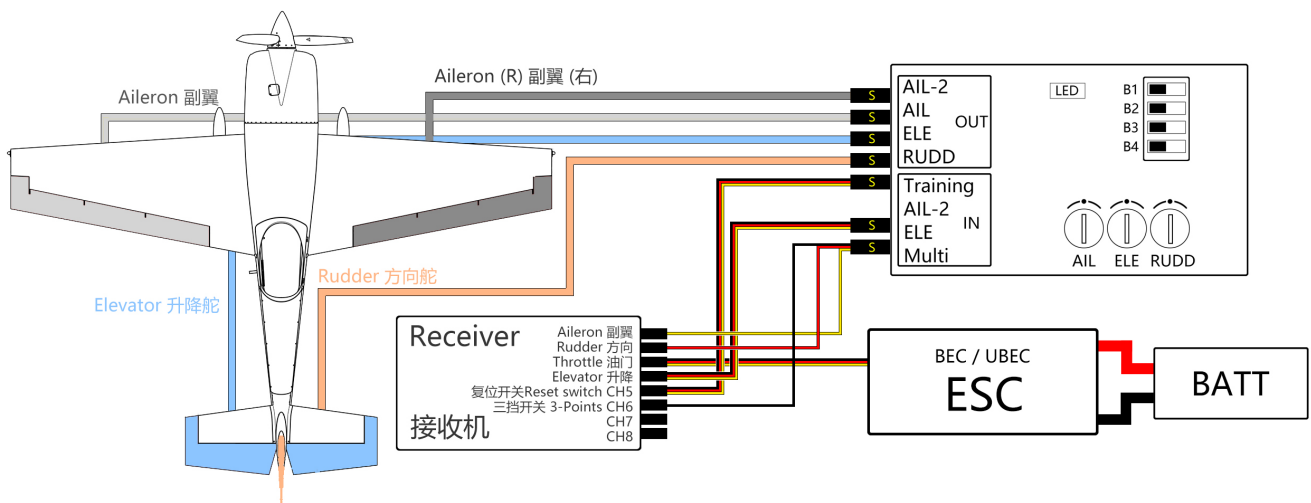

- 左右副翼单独控制 (遥控器需要设置双副翼通道，适用于襟翼副翼混控模式)  
Left and right aileron are independently controlled (remote control require to set up double aileron channel, suitable for flap aileron mixing mode)

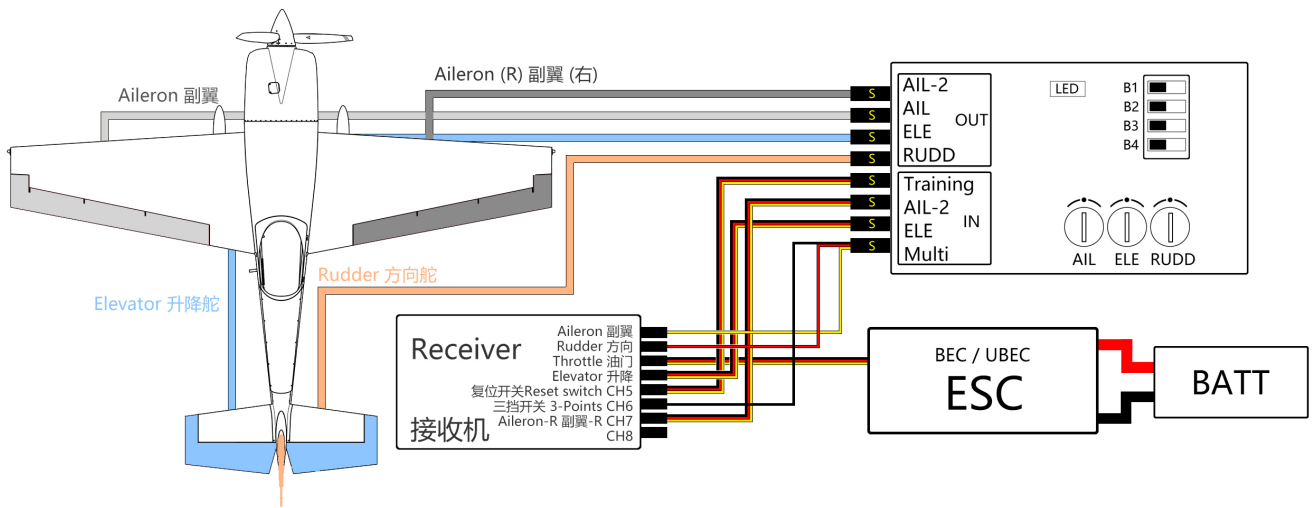

3 通电测试：约5秒后，副翼方向升降三个舵面会较大幅度抖动一次，代表飞控已经启动。

Power test: After about 5 seconds, the three rudder surfaces in the direction of aileron lifting will shake markedly, which means that flight control has been started

※ 第一次连接，可能需要断电重启一次。

The first connection may require a power off restart

### 模式选择/模式说明 Mode selection/Mode description

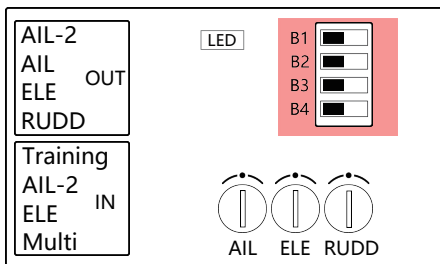

### 飞行模式设置 Flight mode setting

#### 模式-1 副翼平衡模式 Mode -1 Aileron balance mode

此模式将保持机身自稳，限制飞机滚转速度；平尾和垂尾辅助稳定。

This mode will keep the fuselage self-stable and limit the rolling speed of the aircraft; horizontal and vertical tail assisted stabilization.

※ 此模式不支持左右副翼单独控制

This mode does not support the left and right aileron independent control.

※ 此模式副翼的最大角度被限制在 $\pm 75^\circ$

The maximum Angle of the aileron in this mode is limited to  $\pm 75^\circ$

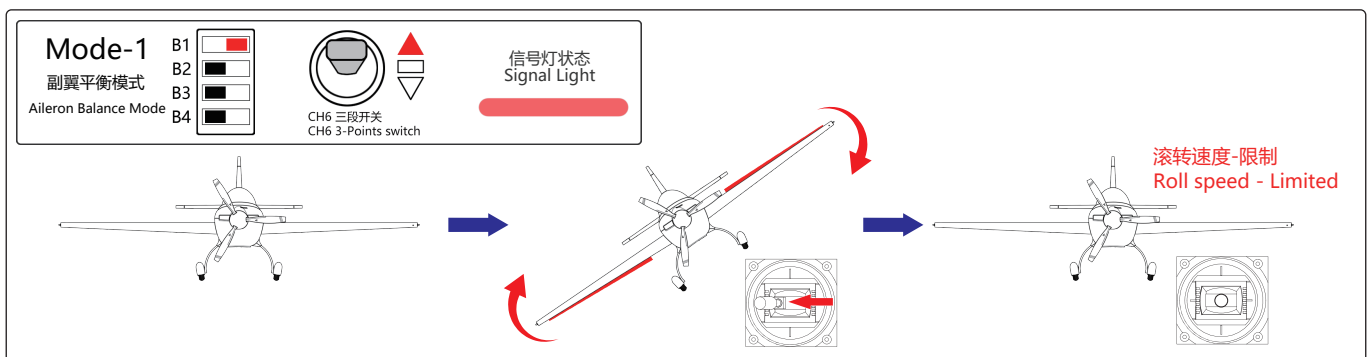

**模式-2 副翼锁定模式**  
**Mode 2 - Aileron lock mode**

此模式会将飞机姿态锁定，限制飞机滚转速度；平尾和垂尾辅助稳定。

This mode will lock the attitude of the aircraft and limit the rolling speed of the aircraft. Horizontal and vertical tail assisted stabilization.

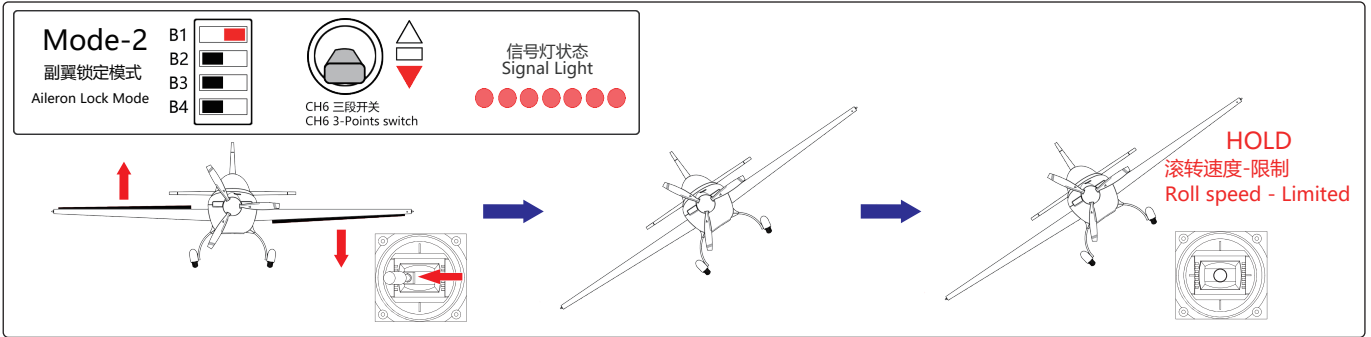

**模式-3 副翼增强模式**  
**Mode 3 - Aileron enhancement mode**

此模式会将飞机姿态锁定，略微限制飞机滚转速度，平尾和垂尾辅助稳定。

This mode will lock the attitude of the aircraft and limit the rolling speed of the aircraft slightly. Horizontal and vertical tail assisted stabilization.

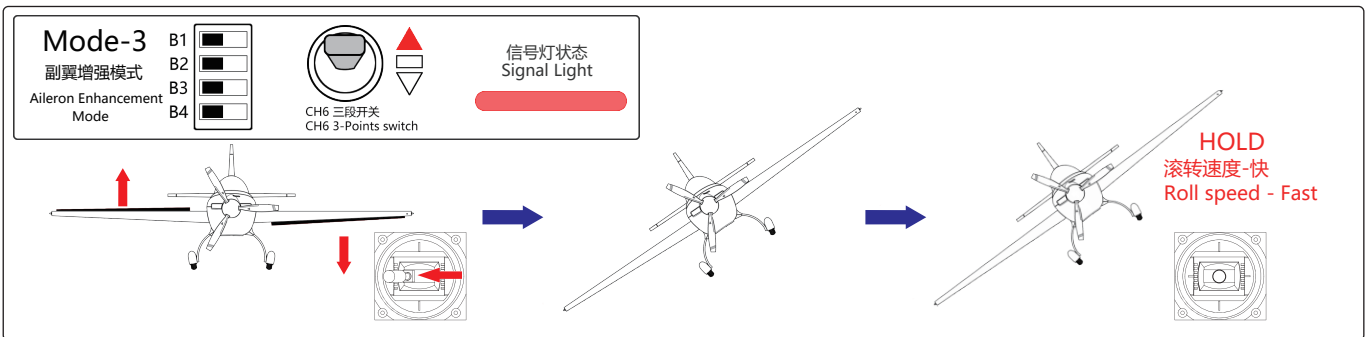

**模式-4 抗风模式**  
**Mode 4 - Wind Resistant mode**

此模式会将飞机姿态锁定，平尾和垂尾辅助稳定。

This mode will lock the aircraft attitude, horizontal tail and vertical tail to assist stability.

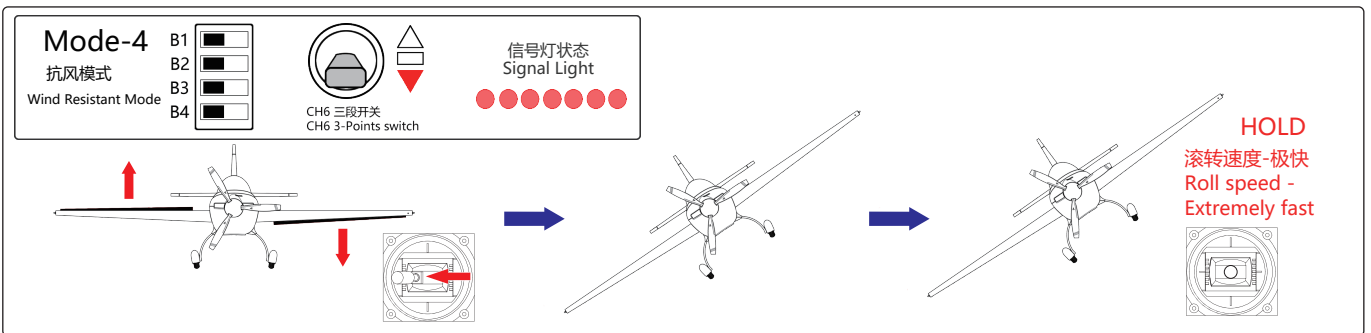

**模式-5 一键救机模式**  
**Mode 5 - One-click Rescue Mode**

此模式会先将机身姿态以较快的速度调整为水平，然后抬高水平尾翼舵面使机体拉升。

In this mode, the fuselage attitude is adjusted to the level at a faster speed(quickly), and then the horizontal tail rudder is raised to pull the body up.

**Mode-5**  
 一键救机模式(飞控正常工作中)  
 One-click Rescue Mode  
 (When the flight control  
 department is working normally)



CH5 复位开关  
CH5 Momentary

信号灯状态  
Signal Light



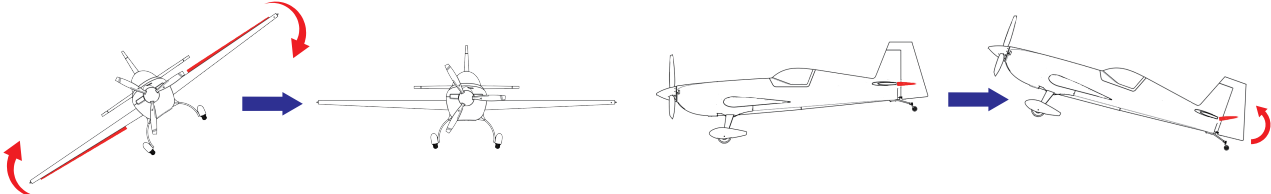

- ※ 此模式需要保持开关位置，待救机完成后才能复位开关。  
 This mode needs to keep the switch position, and the switch can be reset after the rescue is completed.
- ※ 此模式依然需要控制油门大小。  
 This mode still requires throttle control.
- ※ 若水平尾翼不是抬高而是降低，可使用下图方式将平尾舵面反向。  
 If the horizontal tail is not raised but lowered, the horizontal tail rudder can be reversed according to the following method.

**Mode-5R**  
 一键救机模式---水平尾翼反向  
 One-click Rescue Mode  
 Horizontal Tail Reverse

B1

B2

B3

B4



**模式-6 垂尾姿态锁定功能打开/关闭**  
**Mode-6 The vertical tail attitude lock function is on/off**

打开/关闭垂尾姿态保持功能  
 Turn on/off the vertical tail  
 posture maintenance function

B1

B2

B3

B4

**模式-off 关闭飞控**  
**Turn off flight control**

任何模式下，将三段开关至于中间位置，即可关闭飞控的所有功能（含一键救机功能）。  
 In any mode, put the 3-points switch in the middle position to turn off all functions of flight control (including one-click rescue function).

**Mode-off**  
 手动模式  
 Manual Mode

B1

B2

B3

B4

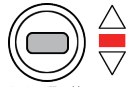

CH6 三段开关  
CH6 3-Points switch

信号灯状态  
Signal Light



**敏感度设置 Sensitivity setting**

AIL-2  
 AIL OUT  
 ELE  
 RUDD

LED

B1

B2

B3

B4



AIL ELE RUDD

Training  
 AIL-2 IN  
 ELE  
 Multi

1 敏感度设置是使用飞控飞行的重要环节。当旋钮对准12点方向时，飞控对应的通道不参与活动。

Sensitivity setting is an important part of flight control. When the knob is aligned to the 12 point direction, the corresponding channel of flight control does not participate in the work.

2 建议敏感度从低到高慢慢调试，12点敏感度为0；越靠近5点/7点方向敏感度越大。请注意，过高的敏感度会影响飞行。

It is recommended to debug the sensitivity slowly from low to high, and the sensitivity is 0 at 12 o'clock; The closer you get to 5 / 7, the greater your sense of direction. Please note that excessive sensitivity can affect flight.

3 以AIL副翼舵面为例，当旋钮向左/右旋转的时候飞控会开始工作，旋转角度越大，飞控灵敏度越高。当灵敏度超过阈值，飞控会过度修正导致飞行中的固定翼抖动。飞机不同阈值亦不同。

Take AIL aileron rudder surface as an example, flight control will start to work when the knob is rotated left/right. The greater the rotation angle, the higher the flight control sensitivity. When the sensitivity exceeds the threshold, the flight control overcorrects and causes fixed-wing jitter in flight. The threshold is different for different aircraft.

4 飞行状态中，若无法锁定，则感度过低，若飞机抖动，则感度过高。

In the flight state, if it cannot be locked, the feeling is too low; if the aircraft jitter, the feeling is too high.

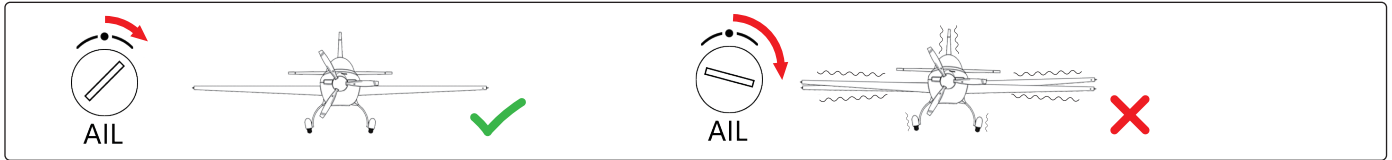

5 当舵面修正方向相反时，请将敏感度调整到另外半圈。When the rudder surface is corrected in the opposite direction, please adjust the sensitivity to the other half turn

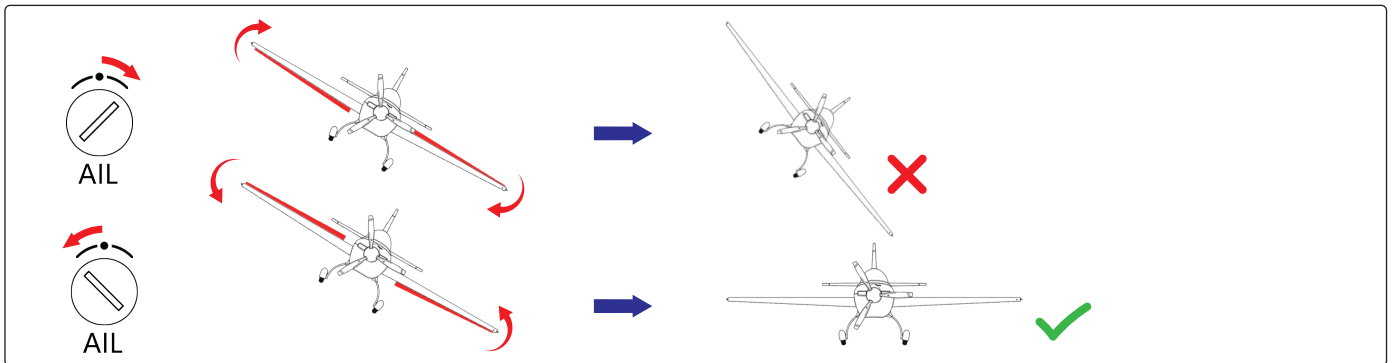

### 对应机型选择 Select a model

机型对应选择，三角翼机型打开B3，V尾机型打开B4。

Select the corresponding model, open B3 for delta wing model and B4 for V-tail model.

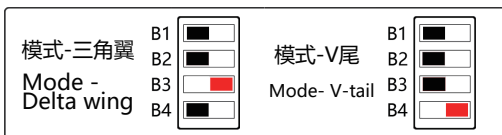

### 保存中立点 Save neutral point

若切换模式时舵机会漂移，则可以通过断电自检，或者重设中立点来解决。

If the steering gear(servo) will drift when switching modes, it can be solved by power off and self-test, or reset the neutral point.

更换新的适配机型或者遥控器时，大多需要重新保存中立点信息，快速切换遥控器的模式开关3次，（CH6三段开关）将自动保存当前舵机中立点。

When replacing the new adaptive model or remote control, most need to re-save the neutral point information, quickly switch the mode switch of the remote control three times, (CH6 three-stage switch) will automatically save the current steering gear neutral point.

### 其他 Other

1 调试飞控时请先**锁定油门**，或者**取下桨叶**。

When debugging flight control, please lock the throttle or remove the propeller.

2 请确认机械部分正常工作，比如较长的平垂尾连杆因为阻力过大，可能会影响飞控控制舵面。

Please confirm that the mechanical part is working normally. For example, the longer horizontal vertical connecting rod may affect the flight control rudder surface due to excessive resistance.

3 速度越快的飞机如涵道机、竞速机等感度需要越低，；速度越慢的飞机如练习机，滑翔机等感度需要越高。

The faster the speed of the aircraft such as ducted fan aircraft, racing aircraft, etc., the lower the sensitivity to be required; The slower the speed of the aircraft such as training aircraft, gliders, etc. the higher the sensitivity to be required.