

4D-LI

Suitable for ages over 14

Quadcopter operating instructions

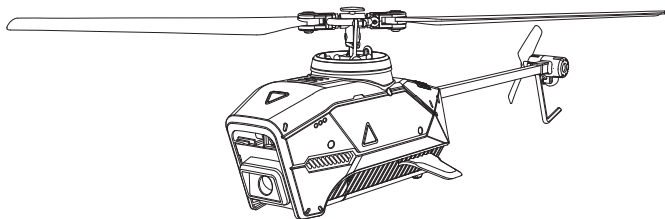

WiFi version

English

- In order to meet the requirements of the aeronautical radio station's electromagnetic environment (various of aero models and UAV are not allowed to fly within the range of 10 km on each side of center line and 20km on both ends of the airport runway and in the) and civil aviation routes and airlines. Using various models and drones in the no-fly zone issued by the relevant state departments is prohibited.

Warning

1. The packaging and instructions contain important information and should be kept.
2. With this aircraft, you are responsible for ensuring that no harm will be caused to the personal and property of others.
3. Commissioning and installing of aircraft must be strictly in accordance with the operating instructions, and attention shall be paid to the distance between the aircraft and the user or other people shall be 2 to 3m to prevent the aircraft from bumping into the head, face and body of people and causing injury in flying and landing, etc.
4. Our company and distributors are not responsible for any loss and damage, as well as injury to people caused by improper use or operation.
5. Children should be guided by adults when operating the aircraft. This product is prohibited to be operated by children under 14 years old.
6. Please follow the instructions or packaging instructions to install and use correctly, and some parts should be assembled by adults.
7. The product contains small parts, please place it out of the reach of children to prevent the risk of accidental eating or suffocation.
8. It is strictly forbidden to play on the road or in the place where water is accumulated to avoid accidents.
9. Please put away the packing materials in time to avoid harm to children.
10. Do not disassemble or modify the aircraft. Disassembly or modification may cause malfunction to the aircraft.
11. The charging cable needs to be inserted into the designated power supply 5V \Rightarrow 2A that is the same as the product label.
12. The use of other charging cables will cause damage to the battery and may cause unexpected dangers.
13. The charging cable is not a toy.
14. When charging the rechargeable battery, it must be under the supervision of an adult. When charging, it must be far away from flammable materials. During charging, the guardian should not leave the monitoring range.
15. Please do not short circuit or squeeze the battery to avoid explosion.
16. Do not mix different types of lithium batteries.
17. The aircraft uses a rechargeable lithium battery, which needs to be pulled out for charging.
18. Do not short-circuit, decompose or throw the battery into fire; do not put the battery in a place with high temperature and heat (such as in fire or near electric heating device).
19. The aircraft should be used as far away from other electrical equipment and magnetic objects as possible, they may cause mutual interference.
20. Please keep a safe distance from the high-speed rotating propeller to avoid the risk of scalp or cut
21. The motor is a hot part; please do not touch it to avoid burns.
22. LED has laser radiation; please do not give direct light beam to others.
23. Do not use the model near your ears! Misuse may cause hearing damage.
24. The USB charging cable must use the data cable provided by our company to charge the battery, otherwise it will cause serious damage to the battery and will lead to unexpected danger.
25. To meet the magnetic environment requirements of aeronautical radio stations. During the radio control order issued by the relevant state departments, the model remote control should be stopped within the city area as required.
26. Turn off the switch and unplug the battery when the battery of the aircraft is used up, and charge after 30 minutes of rest, otherwise the battery will be easily damaged.

1. List of accessories included:



Aircraft ×1



USB charging cable ×1



Propeller ×2

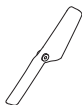

Tail rotor ×1

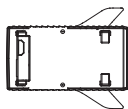

Lithium battery ×1

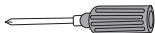

Screwdriver ×1



Operating Instructions ×1

2. Name of each part of aircraft:

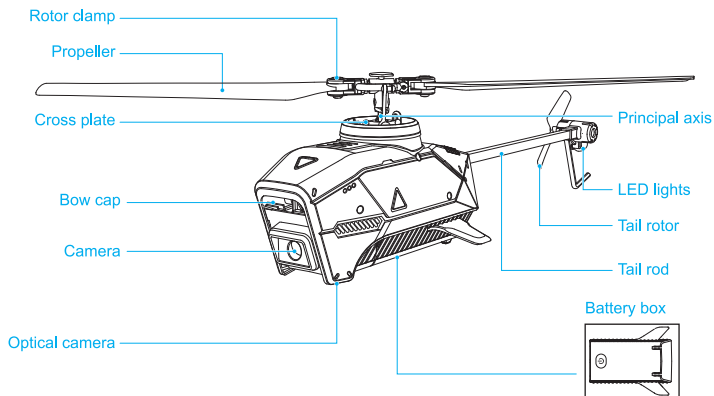

3. Installation diagram of propeller/tail rotor:

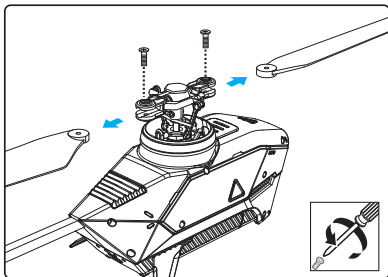

3.1 Unscrew the screws to remove the fan blades.

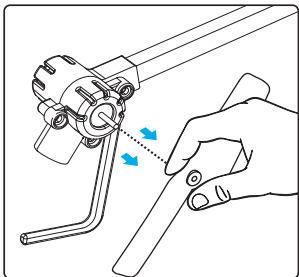

3.2 Hold the middle of the tail rotor and remove both ends of it

⚠ Note: The wind blade is printed with letter A, please install it correctly according to the diagram, otherwise it will not take off

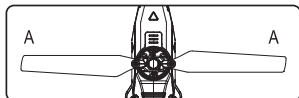

4. Lithium battery charging instructions:

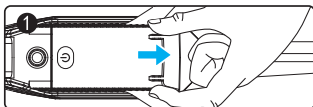

4.1 Secure both ends of the aircraft battery.

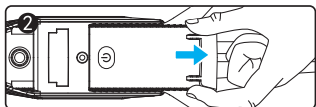

4.2 Remove the battery.

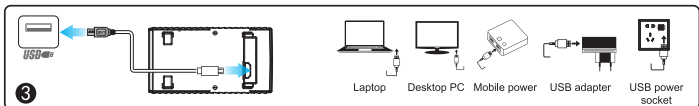

4.3 Charging: Insert the USB port of the USB charging cable into the computer USB port (or use a 5V $\overline{\text{DC}}$ 2A power adapter), and connect the other end of the USB charging cable plug to the battery socket. When charging, the red light will turn on, and when the battery is fully charged, the indicator light will turn off.



It must be charged with the aircraft charging cable provided by the factory, and other charging cables cannot be used. Be sure to remember to avoid accidents.

5. Name of each part of the remote control:

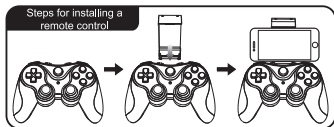
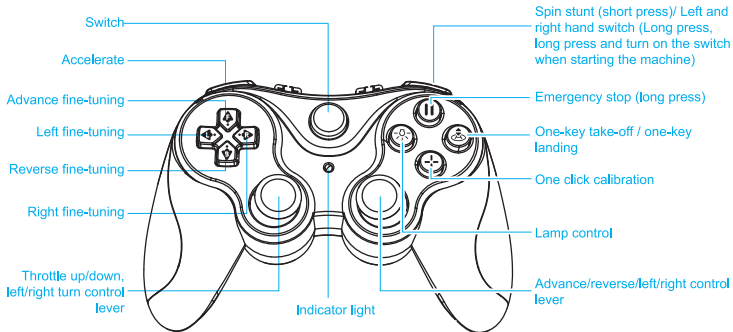

6. Remote control battery installation:

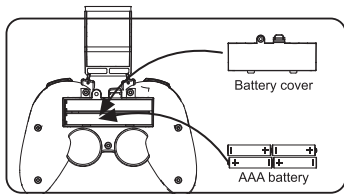

Battery installation:

- 6.1 Remove the battery cover.
- 6.2 According to the polarity instructions on the battery compartment, remove the battery cover on the back, and insert a 4X "AAA" battery (not included).

Instructions in charging:

- Do not put the charged battery in a place with high temperature and heat, such as an open flame or an electric heating device, otherwise damage or explosion may occur.
- Do not hit or beat the surface of hard objects with the battery.
- Do not disassemble the battery.
- Do not immerse the battery in water, and please store the battery in a dry place.
- Do not leave battery alone when charging.

Warning ⚠
When not flying, please do not install the battery in the aircraft to avoid battery damage.

Note

1. The positive and negative poles of the positive and negative poles of the battery box must be identified when inserting the battery, and error is not allowed.
2. Do not mix old and new batteries.
3. Do not mix different types of batteries.

7. Environmental requirements before flight:

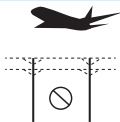

Please choose an outdoor and open environment with no rain and snow and low wind. Please stay away from crowds, trees, wires, tall buildings, airports, and signal transmission towers when flying. Do not fly in a too small indoor environment with lots of things.



APP can only be viewed (photographed/recorded) when using the remote controller, and the remote controller cannot be used when using APP.

8. Preparation instructions before flight

8.1 Fully charge the battery and install it on the body. Short press the power button on the battery twice to turn it on (long press the battery power button to turn it off), and place it on a horizontal surface. At this time, the aircraft placed on the horizontal surface will automatically enter the frequency matching state, and the front blue light and rear red light will flash.

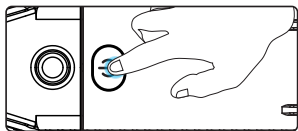

Note: Set the aircraft in a correct direction, and the nose shall face forward. It must be placed on the horizontal plane.

8.2 Press the power switch button “” on the remote control, and the remote control emits a “beep” sound. Push the throttle lever up and then pull it all the way down. Successfully matched the frequency, the drone light will become constantly on.

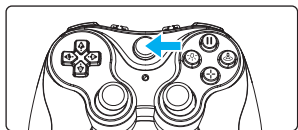

The aircraft/remote controller must ensure sufficient power or it cannot take off!

8.3 Horizontal calibration operation:

Long press the calibration button “” on the remote control, and the LED lights on the aircraft will flash quickly. The LED lights on the aircraft become constantly on, meaning successful calibration (Figure 1).

Note: In calibration, the aircraft must be placed on a horizontal surface to complete the calibration.



Figure 1



8.4 Start/stop

Push the left joystick on the remote control upwards (Figure 2), and the aircraft can take off normally. After takeoff, all indicators of the aircraft remain on. During flight, pressing the button “||” will stop the aircraft from flying (Figure 3).

⚠ Note: This function operation is only suitable for the aircraft in an uncontrolled state. Under normal circumstances, it is recommended to use the one-key takeoff/one-key landing  key.



Figure 2



Figure 3

8.5 One-key take-off and landing

When unlocking is complete, gently press the “One Key Takeoff/Landing” key on the remote control  (Figure 4), the aircraft will automatically rise to a height of about 1 meter to maintain a stable flight; when you press this function key gently again, the aircraft will automatically land slowly.



Figure 4



Operate the aircraft with the remote control. Before taking off, please operate according to the above sequence: Turn on (refer to 8.1) → frequency matching of the remote control starts (refer to 8.2) → horizontal alignment (refer to 8.3) → start/stop (refer to 8.4) → one-button taking off and landing (refer to 8.5)

9. Introduction of remote control function and operation:

9.1 Remote control method:



When the left joystick (throttle) is pushed up, the rotation rate of the main blade increases and the aircraft rises.

When the left joystick (throttle) is pushed down, the rotation rate of the main blade slows down and the aircraft descends.



When the left joystick (rudder) is pushed to the left, the aircraft nose turns to the left. When the left joystick (rudder) is pushed to the right and the nose of the aircraft will turn to the right.



When the right joystick (rudder) is pushed up, the aircraft moves forward.

When the right joystick (rudder) is pushed down, the aircraft moves backward.



When the right joystick (rudder) is pushed to the right, the aircraft fuselage deviates to the right.

When the right joystick (rudder) is pushed to the left, the aircraft fuselage deviates to the left.

9.2 One-click rotation

Short press the one-click-rotation button on the remote control (Figure 5), and the aircraft will rotate twice at its own midpoint before stopping. Pulling the right joystick can also stop rotation at any time.



Figure 5

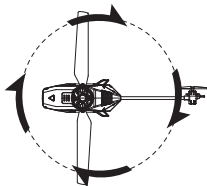

9.3 Speed switching

When the aircraft takes off, it is by default in the low-speed mode (3-gear switching); gently press the remote control by a "beep" sound for low-speed gear, two "beep" sounds for medium-speed gear, and three "beep" sounds for high-speed gear (Figure 6).



Figure 6

9.4 Lighting control

Short press the light mode button "" to turn on/off the lights on the aircraft (Figure 7).



Figure 7



Tail lights

9.5 Normal mode (Optical flow assisted positioning)

The aircraft enters the normal mode: when flying above a good ground, optical flow will assist the aircraft. When hovering in a place, it will be normal to drift about 1 meter depending on the ground and altitude conditions.



9.6 Fine tuning function



1. Forward fine adjustment: When the aircraft leaves the ground and moves backward, press and hold the forward fine adjustment button to make adjustments.



2. Backward fine adjustment: When the aircraft leaves the ground and moves forward, press and hold the backward fine adjustment button to make adjustments.



3. Left flying fine adjustment: When the aircraft leaves the ground and deviates to the right, press and hold the left flying fine adjustment button to make adjustments.



4. Right flying fine adjustment: When the aircraft leaves the ground and deviates to the left, press and hold the right flying fine adjustment button to make adjustments.

10. APP download and installation instructions:

10.1 Download and install the software

For Android mobile phone, after scanning the code, choose to open and download in the browser



10.2 Link description

- ① Turn on the power of aircraft, enter the (Settings) option (of mobile phone or IPAD), and open the wireless network; find the device name of "4DRC*****" in the wireless network search list and connect; after connection, exit the setting option.
- ② Open the software icon "4DRC Air" in mobile phone to enter the control interface. (Try to stay away from other signal source environments when flying)

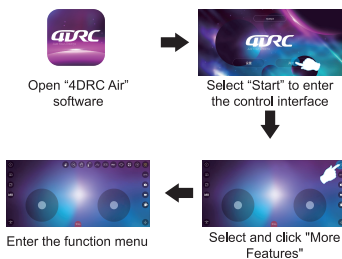

11. APP control interface function introduction:

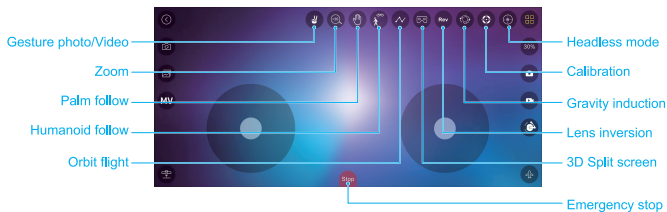

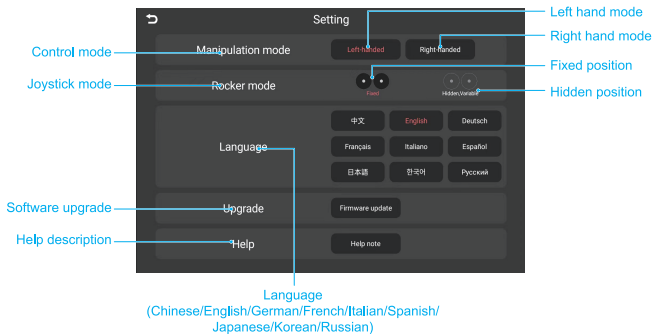
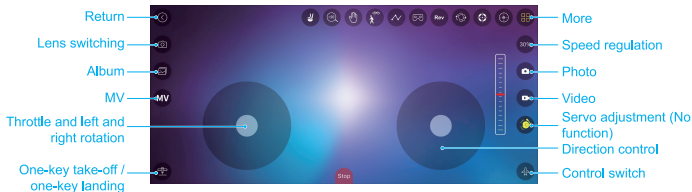

12. Pre-flight preparation instructions (using APP):

- 12.1 Fully charge the battery and install it on the body. Short press the power button on the battery twice to turn it on (long press the battery power button to turn it off), and place it on a horizontal surface. At this time, the aircraft placed on the horizontal surface will automatically enter the frequency matching state, and the front blue light and rear red light will flash.

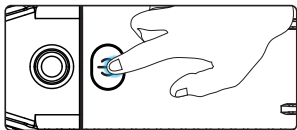

Note: Set the aircraft in a correct direction, and the nose shall face forward. It must be placed on the horizontal plane.

12.2 Enable the WiFi function in the mobile device, select "4DRC *****" in the WiFi list (Figure 8), and after successfully connected, open the APP. Click "Start" (Figure 9) to enter the operation interface. The aircraft light will remain constantly on, which indicating successful frequency matching.



Figure 8



Figure 9

12.3 Horizontal calibration operation:

APP Application operation: click the "correction" icon in the app interface. The LED light on the aircraft flash and the calibration of the LED light on the aircraft is completed (Figure 10).



 **Note:** In calibration, the aircraft must be placed on a horizontal surface to complete the calibration.

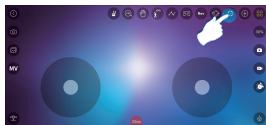

Figure 10



12.4 One-key take-off and landing

APP operation: Click the "one-key take-off"  icon (Figure 11) in the APP control interface, and the one-key takeoff function can also be realized; during the flight, click the "one-key landing"  icon, and the aircraft will automatically land slowly.

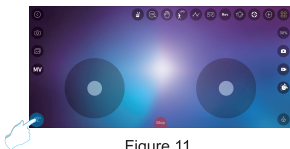

Figure 11



APP operation: Before taking off of the aircraft, please follow the steps in the above sequence: turn on (refer to 12.1) → APP start the frequency matching (refer to 12.2) → level calibration (refer to 12.3) → one key take-off and landing (refer to 12.4)

13. APP Application function operation introduction:

13.1 Remote control method:



When the left joystick (throttle) is pushed up, the rotation rate of the main blade increases and the aircraft rises.

When the left joystick (throttle) is pushed down, the rotation rate of the main blade slows down and the aircraft descends.



When the left joystick (rudder) is pushed to the left, the aircraft nose turns to the left. When the left joystick (rudder) is pushed to the right and the nose of the aircraft will turn to the right.



When the right joystick (rudder) is pushed up, the aircraft moves forward.

When the right joystick (rudder) is pushed down, the aircraft moves backward.



When the right joystick (rudder) is pushed to the right, the aircraft fuselage deviates to the right.

When the right joystick (rudder) is pushed to the left, the aircraft fuselage deviates to the left.

13.2 Speed switching

APP Application operation: click the "30%" icon in the app control interface to switch the flight speed of the aircraft (Figure 12).

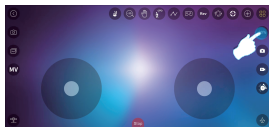



Figure 12

13.3 Gesture recognition

When facing the camera's front lens, click the gesture photo button on the APP, and use any of the following gestures to trigger the aircraft's photo or camera function.

 **Special tip:** Please aim directly at the lens and perform gesture recognition at a position about 2-3M away from the lens and in an environment with good light and background.

Yeah gesture photo



In about 3m front of the aircraft lens, make Yeah gesture with one hand in horizontal position; after the aircraft successfully recognizes the gesture, count down 3 seconds and take photos.

Palm gesture video-recording



In about 3m front of the aircraft lens, put five fingers together and lift one hand to horizontal position; after the aircraft successfully recognizes the gesture, it will start recording. The recording will end when the gesture is re-recognized (the time difference between the two recognitions shall be greater than 3s).

14. FAQ and solving guidelines:

Question	Reason	Solution
The aircraft indicator flashes without any response	The aircraft has insufficient power	Charge the battery
The aircraft's blades rotate but the aircraft cannot fly	1. Low battery 2. Blade deformation	1. Charge the battery 2. Replace the fan blades
The aircraft vibrates badly	1. Blade deformation 2. The splayed buckle falls off or is not installed properly on the ball head	1. Replace the fan blades 2. Properly installed
Fine tuning is done but still can't make the aircraft stable	1. Blade deformation 2. Defective motor 3. The splayed buckle falls off or is not installed properly on the ball head	1. Replace the fan blades 2. Replace the motor 3. Properly installed
After the impact, start the aircraft again and it fly uncontrollably	1. The three-axis acceleration sensor loses its balance due to impact 2. The splayed buckle falls off or is not installed properly on the ball head	1. After leaving the aircraft for 5-10 seconds, or by the horizontal calibration, it will be ok. For the steps, please refer to the manual, 12.4 horizontal calibration operation. 2. Properly installed

