

Aviation band receiver

Suite manual V3.1

A simple introduction

This suite is dedicated to receive calls between aircraft and tower, cooperate with the good performance of the antenna (VHF yagi antenna), open within about 190 km in the biggest can receive calls between various types of aircraft with the control tower.

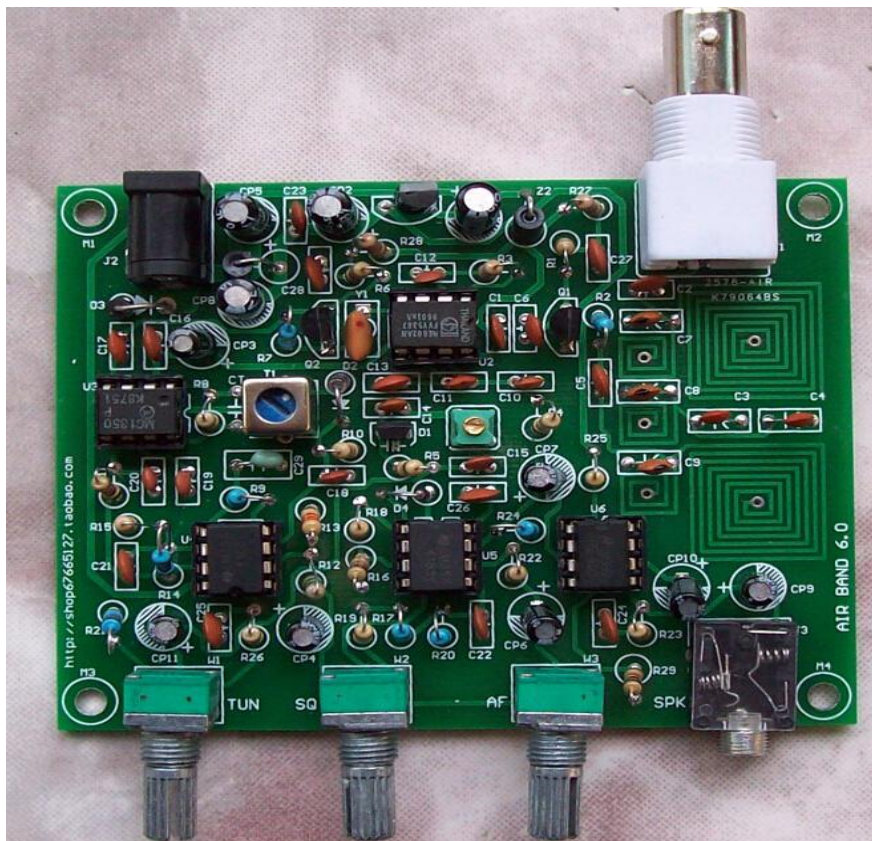

Main indicators

- Power supply: 12 v
- Antenna: 50 ohms, is not balanced
- Typical receiving current: 30 ma
- Receive frequency: 118 MHZ to 136 MHZ
- Working pattern: AM

Circuit principle

Antenna to receive signals first enter a band-pass filter, the band-pass filter function is to ensure that the 118 MHZ to 136 MHZ signal can be put into 2 sc3355 high, other signal is maximum attenuation. After filtering, the signal amplified by the 25th sc3355 (2), and then enter the NE602 mixing, at the same time NE602 inside a voltage-controlled oscillator, the frequency changes because of the

D1 junction capacitance, design covers about 120 MHz to 150 MHz.

Native intermediate frequency is 10.7 MHz, after NE602 mixing signal to 10.7 MHz ceramic filter, its function is to filter out irrelevant signals generated by mixing, and then the signal to do into Q2, finally gave MC1350 further intermediate frequency amplifier. MC1350 amplified signal, in the weeks after the T1 frequency selective, D2 for amplitude modulation signal envelope detection.

Check out the audio signal after U4A and U5B, LM386 amplification for headphone output again.

Among them, the AGC function performed by U4A and U4B, mute function by U5A, U5B to cooperate to complete.

Component selection

All less than 1000 pf the capacitors for high frequency of ceramics, greater than 1 uf capacitance for aluminum electrolytic capacitors, all resistance is a quarter w 5% fixed resistance.

Production debugging

Control circuit diagram and the identity of the PCB mounting of all components. General compliance installation sequence of low to high. Checked everything is in order, after turn on the juice and the power of positive and negative polarity must not be wrong. Insert the walkman headphones headphone socket, should be white noise could be heard. Touch one end of the detector diode, audio headphones get bigger noise description function is normal. To the antenna connected to a soft line of 60 cm, will hear a noise significantly larger, mean channel essentially normal.

Because of all the inductance walked straight line on the PCB, and high precision, no need to be adjusted. Such as near no carrier signal, advice from C5 to 60 centimeters or so at the end of the software, then short circuit R21, so the vibration of the coverage has reached around 100-150 MHz, judge machine can listen to the local FM signal.

Native function knob from left to right are: frequency control, noise threshold adjustment, volume adjustment, clockwise. Headphone socket on the right.



Method of use

For VHF are close to a straight line transmission, therefore VHF communication cannot be obscured, listening to the tower signal more need to pay attention to it, close to the airport in a plane is apart from the ground height when there are several hundred to several thousand meters high, so the signal can cover a distance. In order to better effect, it is recommended to use external high antenna, such as a quarter wavelength (60 cm) of GP antenna, yagi antenna or using better VHF paragraph. In a word, need according to the practical environment, appropriate cooperates antenna, can obtain good result!

For primary fans, it is recommended to use GP antenna or yagi antenna. Below is GP antenna, GPS antenna is short for flat ground antenna, the antenna, also known as vertical ground antenna is a kind of common vertical polarization omnidirectional antennas. It consists of a vertical level of radiation oscillator and 3-4 root extension of the oscillator. A few metal rod with a M, made simple.

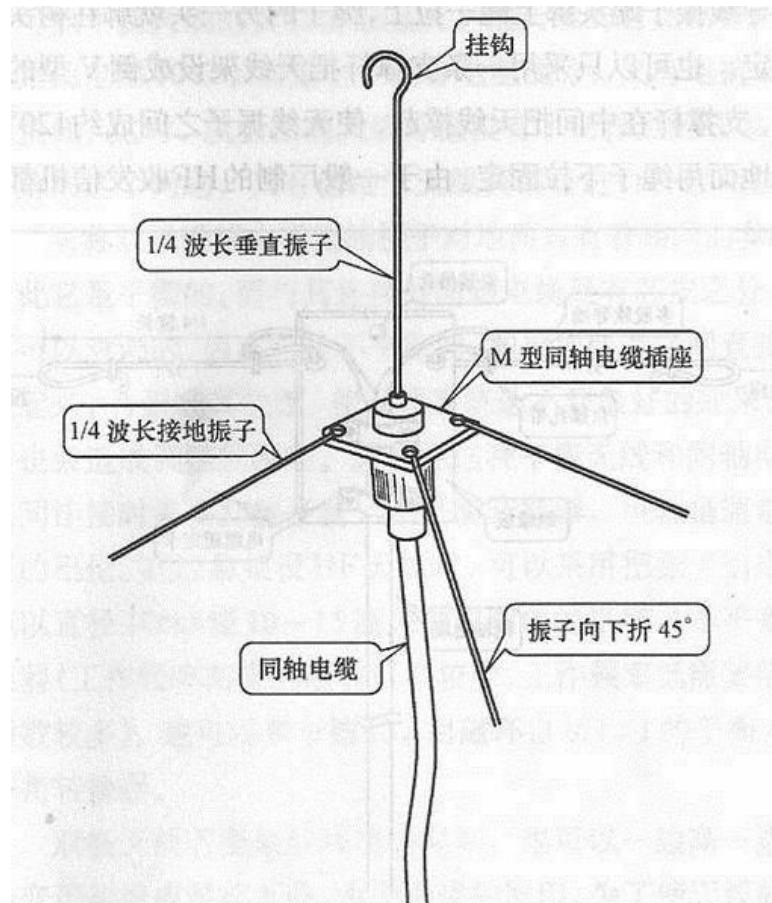

Below as the yagi antenna, has the very good directivity and high gain.

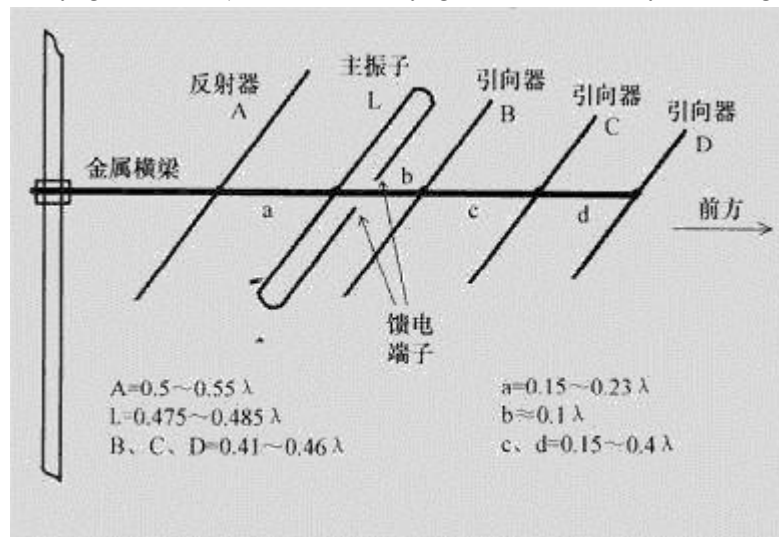

Also can use insulators metal bar! Diagram for wavelength λ , director, reflector are calculated respectively and the main oscillator length and a, b, c, d spacing after assembled.



Chassis to install

This circuit board can be easily in the size of 40 mm * 97 mm * 75 mm standard aluminum chassis (this case is not included in this kit, such as the need to please buy).



元件清单

1/4W 固定电阻		
R1,R6,R11,R16,R29	1K	
R2,R7,R9,R14,R17, R20, R24	47K	
R3,R27,R28	270	
R4,R8,R10,R15,R22	10K	
R5,R18	100K	
R12	1M	
R13	33K	
R19	4.7K	
R23,R25,R26,R21	10	
W1,W2,W3	10K	
磁珠、电感、变压器		
T1	7X7-10.7MHz	
Z1,Z2	直插磁珠	
瓷片电容		
C1,C16,C21,C22,C23,C24, C25,C26,C27,C28	0.1uF(104)	
C2,C5,C6,C13,C17	1000pF(102)	
C3,C4	2pF	
C7,C8,C9	43p	
C10,C14	27pF	
C11	10pF	
C12,C15,C18,C19,C20	0.01uF(103)	
C29	0.47uF(474)	
电解电容		
CP1,CP2,CP5,CP8	100uF /25V	
CP3,CP4,CP7,CP9,CP10,CP1	10uF /25V	

CP6	10uF	
晶体管		
D1	BB910	 插入板子请按丝印方向
D2	检波二极管2AP9	
D4	1N4148	
D3	1N4001	
Q1,Q2	2SC3355	
集成电路		
U1	78L08 (TO92)	
U2	NE602 (DIP8)	配 IC 插座
U3	MC1350 (DIP8)	配 IC 插座
U4,U5	LM358 (DIP8)	配 IC 插座
U6	LM386 (DIP8)	配 IC 插座
陶瓷滤波器		
Y1	10.7MHz	 请注意管脚方向：器件表面印刷字面对读者，1 脚在右边
其他元件		
J1	BNC (Q9) 插座	
J2	电源插座	
J3	3.5mm 立体声插座	SPK (插入耳机)
PCB 电路板×1 片		

R29 / 1K

R29 in LM386 3 between foot and ground, Can improve the response speed of noise, Please welding on the back of the PCB.

CT has been welded in T1 weeks inside, no need to install.

电路板装配

Please note that Y1 1 foot, can not install error!



航空波段接收机电路图 (V3.0)

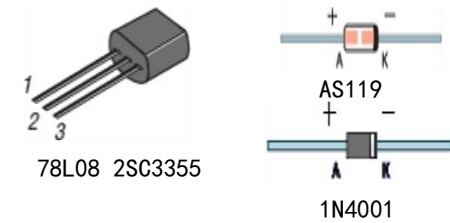
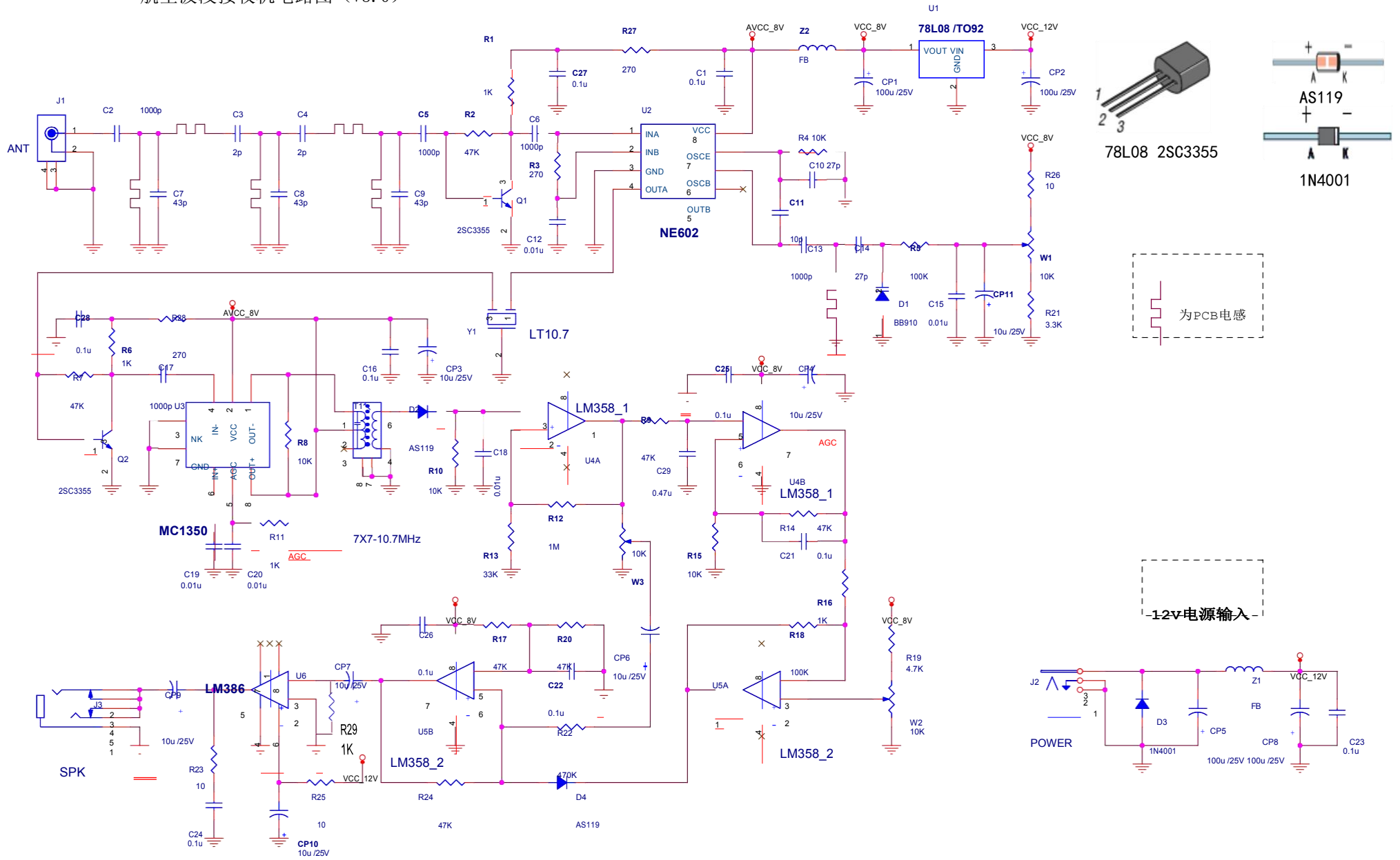

为PCB电感

-12v电源输入-

- M1 HOLO
- M2 HOLO
- M3 HOLO
- M4 HOLO

Title		01.MAIN	
Size	Document Number	Rev	