



# UH-1D Scale Helicopter User Manual

## E190



## Table of Contents :

|   |    |
|---|----|
| Introduction .....                                  | 1  |
| Accessory List .....                                | 1  |
| Caution .....                                       | 2  |
| Warning .....                                       | 2  |
| Safety Precautions and Warnings .....               | 2  |
| Helicopter Specifications .....                     | 3  |
| Warnings and Battery Usage Guide .....              | 3  |
| Battery Charging .....                              | 3  |
| Battery Functions and Indicators .....              | 4  |
| Remote Control Functions .....                      | 5  |
| Aircraft and Remote Control Frequency Binding ..... | 6  |
| Aircraft Status Indicator Light Explanation .....   | 6  |
| Gyroscope Calibration .....                         | 7  |
| Manual Motor Start/Stop .....                       | 7  |
| Aircraft Locking .....                              | 8  |
| First Flight .....                                  | 8  |
| Main Control Board Socket Diagram .....             | 9  |
| Optical Flow Mode Precautions .....                 | 9  |
| Manual Mode Flight .....                            | 10 |
| One-Key Landing .....                               | 11 |
| Expert Reverse Flight Mode .....                    | 11 |
| Pitch Setting .....                                 | 12 |
| Common Troubleshooting .....                        | 12 |

## Introduction:

This model is a 1:34 scale replica of the UH-1D helicopter, featuring highly realistic detailed appearance, cool lighting effects, and equipped with intelligent flight control, Optical flow positioning module, and altitude hold module. With its dual brushless motor drive, it is especially suitable for beginners. It can also serve as an excellent static display model.

Before operating the helicopter, please read this user manual carefully. This manual provides detailed instructions to help you understand the product. Incorrect operation may result in damage to the aircraft model, wasting your valuable time and money.

## What in box:

| No. | Spare parts          | Quantity |
|-----|----------------------|----------|
| 1   | Blister Packaging    | 1        |
| 2   | User Manual          | 1        |
| 3   | Helicopter           | 1        |
| 4   | Transmitter          | 1        |
| 5   | USB Cable            | 1        |
| 6   | Battery 1200mAh 7.4V | 1        |
| 7   | Main Rotor Blade     | 2        |
| 8   | Tail Rotor           | 1        |

## Caution:

Our company reserves the right to change all specifications, warranties, and other accompanying documents. Please contact us for the latest product information.

## Warning:

Please read the entire user manual before operating the product to familiarize yourself with its functions. Failure to operate the product correctly may result in product damage, personal and property losses, and cause serious injury. This is a complex hobby product that requires careful and sensible operation, as well as some basic mechanical skills. Failure to operate this product responsibly and in a safe manner may result in personal injury, damage to the product, or other property. This product is not intended for use by children without direct adult supervision. This manual contains safety, operational, and maintenance instructions. It is essential to read and follow all instructions and warnings in the manual before assembly or use to ensure proper operation and to avoid damage or serious injury.

## Safety Precautions and Warnings:

1. Age Recommendation: Not suitable for children under 14 years old. This is not a toy.
2. Always operate your model in an open space away from vehicles, traffic, and people.
3. Follow operating notices, warnings, and any supporting equipment instructions (charger, batteries, etc.) carefully.
4. Keep away from any chemicals; keep small parts and electrical components away from children.
5. Always stay away from water, especially as this product is not waterproof; it will be damaged by moisture.
6. Do not put any part of the model in your mouth, as it may cause serious injury or even death.
7. Do not operate your model using low-voltage transmitter batteries.

## Helicopter Specifications:

|                        |                  |
|------------------------|------------------|
| Length                 | 385 mm           |
| Height                 | 125 mm           |
| Weight                 | 290 g            |
| Main Rotor Diameter    | 375 mm           |
| Tail Rotor Diameter    | 70 mm            |
| Battery Specifications | 7.4V 1200mah 25C |
| Flight Time            | 10–12Min         |
| Main Brushless Motor   | 2511             |
| Brushless Tail Motor   | 1204             |

## ⚠ Warnings and Battery Usage Guide:

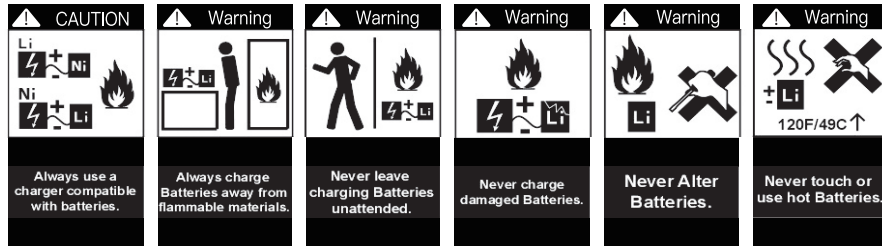

For safety purposes, please use the provided standard charger.

⚠ Warning: It is strongly recommended to use the included charger for battery charging.

⚠ Caution: Lithium batteries may be damaged and may not charge properly when the voltage drops below 7.4V.

## Battery Charging:

1. Connect the USB cable to a computer USB port or a power adapter.
2. Connect the USB's other end (Type-C plug for Android) to the battery for charging.
3. During charging, the current battery level indicator will flash, and all four lights will remain solid when charging is complete.
4. Disconnect the charging connection after charging is complete.

Note: It is recommended to use a 5V 2A adapter for charging, as it will enable faster charging.

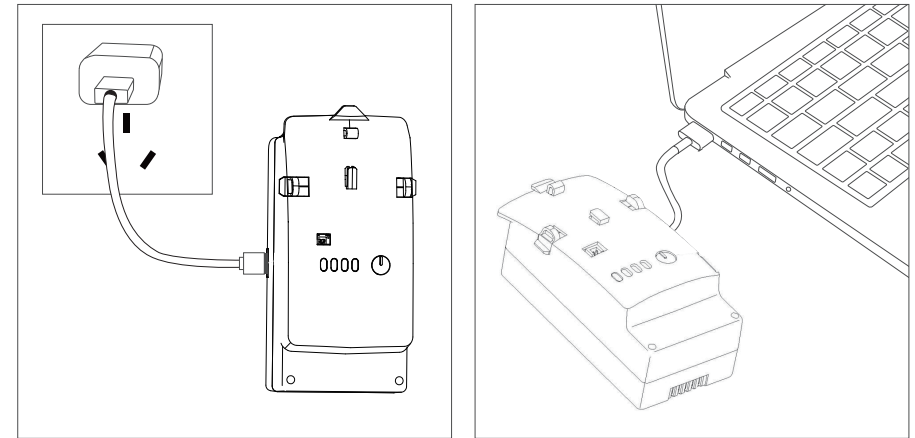

## ⚠ Warning:

1. To ensure maximum safety, monitor the battery while it is charging.
2. Do not allow children to charge the battery on their own, but ensure that an adult supervises the entire process.

## Battery Functions and Indicators:

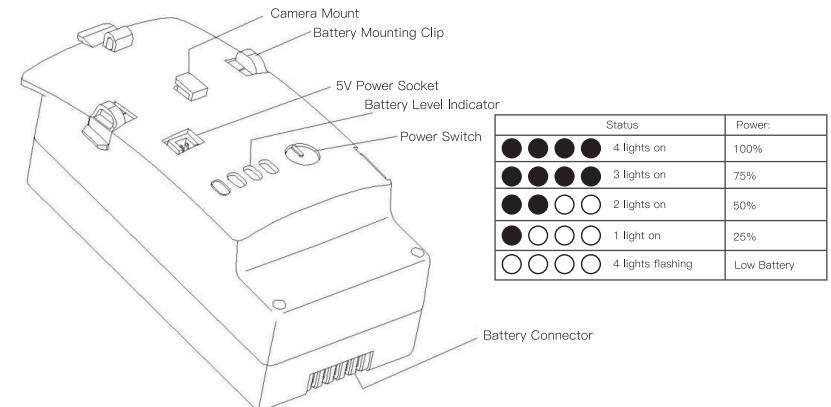

## ⚠ Warning:

After use, please turn off the battery as prolonged power-on time may shorten the battery lifespan. After flying, remove the battery from the cabin to prevent damage due to over-discharge.

## Transmitter Functions:

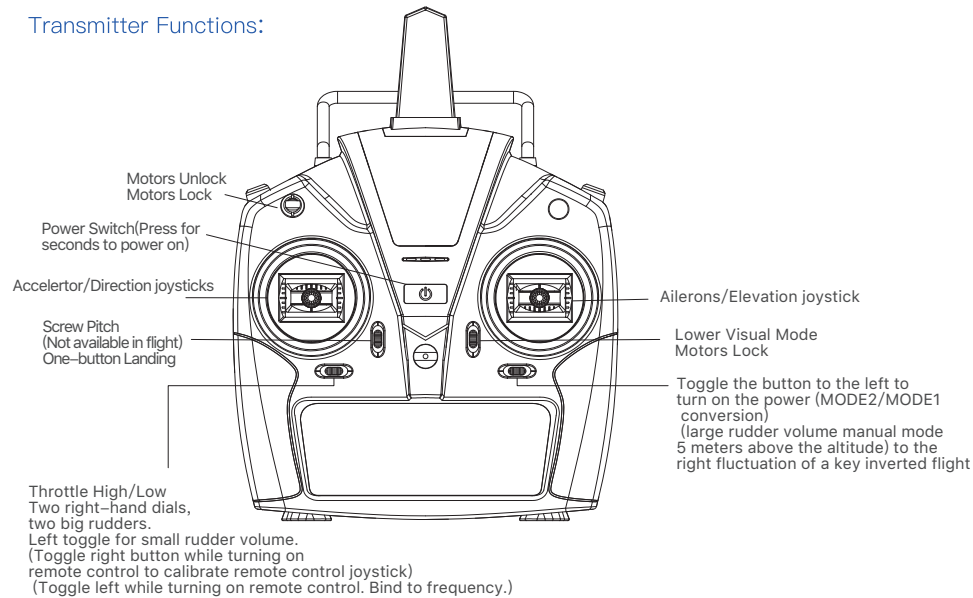

### ⚠ Caution:

1. The factory default mode is MODE2, with the remote control lighting up blue. Press the MODE button to power on and switch to MODE1 mode, with the remote control lighting up red and blue lights.
2. To calibrate the remote control joystick, move the size of the rudder control button to the right and power on, the remote control will beep three times, keep the remote control still to calibrate.
3. The remote control is set to small rudder volume by default when it leaves the factory. Move the button to the right for two beeps to set to large rudder volume, move the button to the left for a beep to set to small rudder volume.

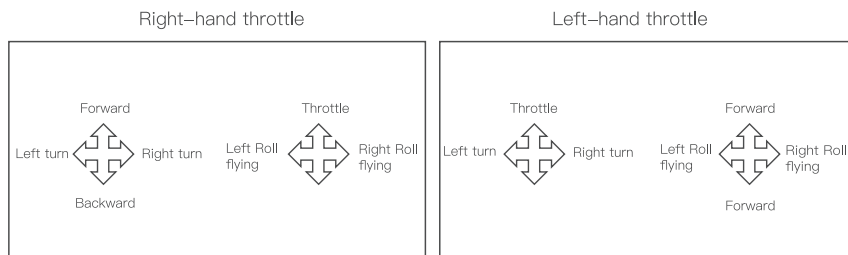

## Aircraft and Remote Control Frequency Binding:

When purchasing the aircraft kit, the remote control already bound to the aircraft at the factory and can be used directly. In other cases, please follow the instructions below for binding.

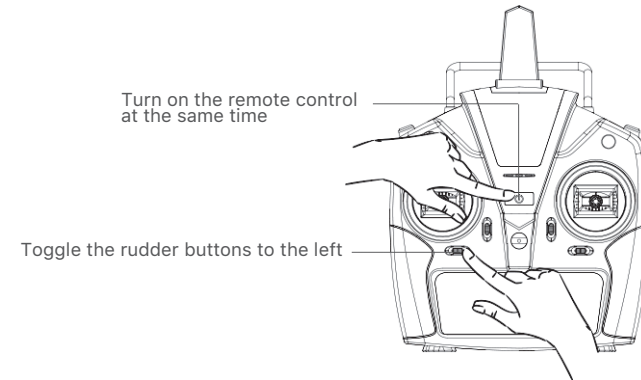

- 1 Toggle the small rudder volume (L) key to the left, at the same time open the remote control to enter the frequency pairing mode, at this time, the remote control will emit a dropping sound after powering on the remote control, the remote control indicator light flashes fast to enter the frequency pairing.
- 2 Power up the flight and turn on the battery switch, the aircraft indicator light flashes fast to the yellow light.
- 3 Approach the aircraft to the airplane within a distance of 0.5m, and keep the aircraft stationary.
- 4 The remote control emits a dropping sound, and the remote control indicator light lights up, at this time, the aircraft indicator light also returns to green light. The indicator light of the aircraft also returns to the green light, the frequency pairing is completed.
- 5 If the frequency pairing binding is not successful, please repeat the above steps to re-frequency pairing.

## Aircraft Status Indicator Light Explanation:

- 1.Rapid yellow flashing: Aircraft self-checking. The aircraft should remain stationary until the self-check is completed.
- 2.Solid green: Downward visual optical flow mode. Limited to flying at a height of 8 meters.
- 3.Slow green flashing: Poor downward visual environment. Lower the flight altitude or change the flying area.
- 4.Solid red: Manual flight mode. Exercise close attention when flying manually.
5. Slow red flashing: Low-level battery warning. Control the aircraft within visual range.
6. Rapid red flashing: Critical-level battery warning. The aircraft will initiate an automatic landing.

## Gyroscope Calibration:

After successful binding between the aircraft and the remote control, perform the following steps to calibrate the gyroscope. On the remote control (MODE2), hold the left joystick in the upper corner and the right joystick in the lower corner as shown in the diagram for 2–3 seconds. During this time, the aircraft's indicator light will flash yellow and then change to solid green, indicating that the calibration is complete.

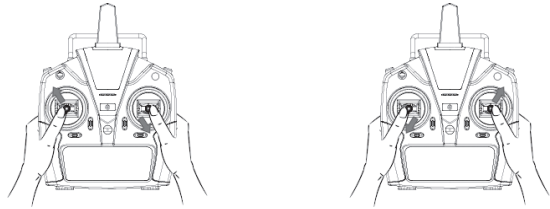

MODE2 (Access gyroscope calibration for Mode 2)    MODE1 (Access gyroscope calibration for Mode 1)

During gyroscope calibration, it is important to place the aircraft on a level surface to ensure accurate flight. The gyroscope is already calibrated at the factory, so users do not need to calibrate it again unless they are unable to exit the initialization or if there is yaw drift in manual attitude mode. In such cases, recalibration is necessary. After successful calibration, the indicator light will provide prompts based on the current position of the remote control's switch, as explained in the indicator light section.

## Manual Motor Start/Stop:

**Motor Start:**  
Perform the throttle stick action to start the motor. Immediately release the stick after starting the motor. Push the throttle stick upward by more than 50%, and the aircraft will take off.

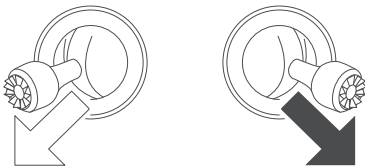

**Motor Stop:**  
How to stop the motor after it starts spinning: After the vehicle lands, the throttle rocker is in the lowest position and held for more than 3 seconds, the motor stops spinning.

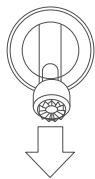

## Aircraft Locking:

Switch down for a long beep to lock, switch up to unlock. Locking while in the air will cause the motor to stop and crash.

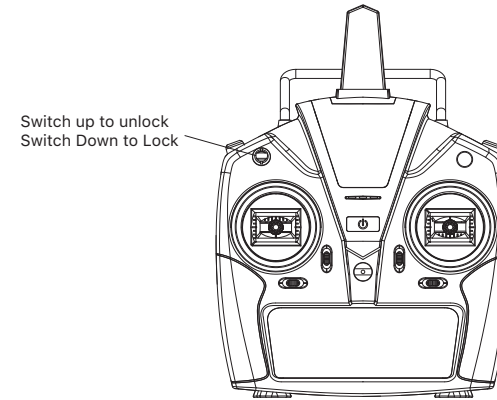

## First Flight:

If you are not familiar with E190, please take a few minutes to familiarize yourself with its controls before attempting your first flight.

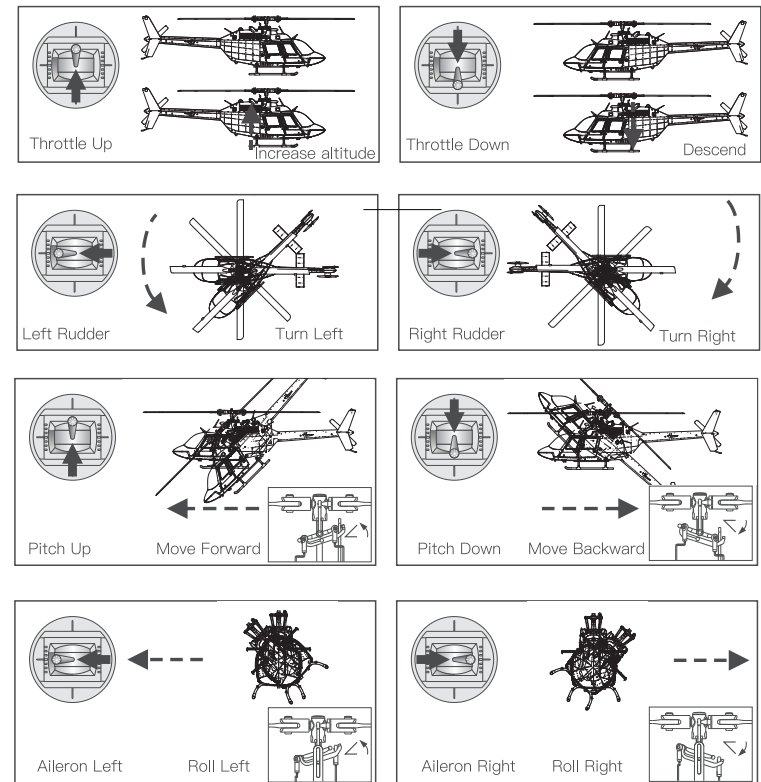

## Main Control Board Socket Diagram:

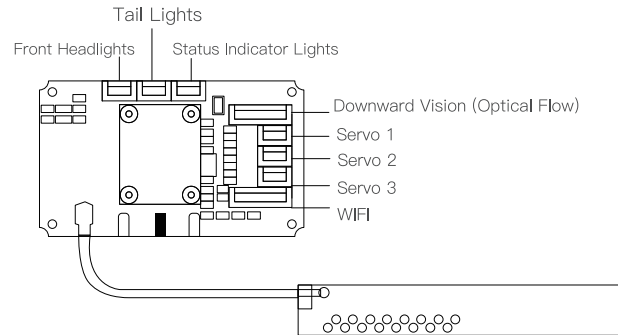

## Notes on Downward Vision Mode:

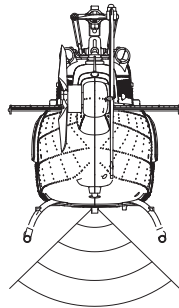

Please pay attention to the surrounding flying environment. The vision system only serves as an auxiliary function under limited conditions. It cannot replace human judgment and control. Users should constantly be aware of the surrounding environment during flight, maintain control over the aircraft throughout the entire flight, and take responsibility for their actions.

The downward vision system relies on the camera to lock onto objects below and limits the takeoff altitude to 8 meters. Please avoid taking off from rooftops or flying over rooftops, as it may cause the downward vision to fail, resulting in aircraft drift. In such cases, immediately fly the aircraft back or switch to manual stability mode.

The downward vision system cannot recognize surfaces without textured features and cannot function properly in environments with insufficient or excessive lighting. The following scenarios are where the downward vision system cannot work:

1. Solid color surfaces (e.g., solid black, solid white, solid red, solid green)
2. Surfaces with strong reflections or reflections
3. Water surfaces or surfaces of transparent objects
4. Surfaces of moving objects (e.g., above crowds, bushes, and grasses swaying in strong winds)
5. Scenes with rapidly changing lighting conditions
6. Surfaces that are exceptionally dark or exceptionally bright
7. Surfaces of materials that have strong absorption or reflection of infrared

## Manual Mode Flight:

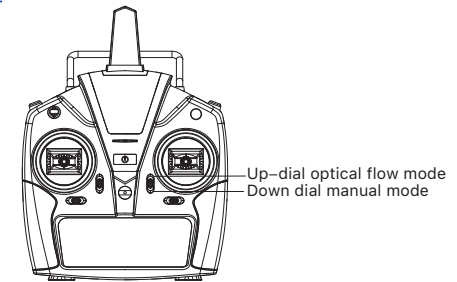

Pressing the manual mode button will turn off the optical flow flight mode, at this time the aircraft status indicator light is red and long light to lift the aircraft altitude restriction, the fastest flight speed can be up to 10 meters per second, please pay close attention to the aircraft to operate carefully. Toggle the optical flow mode button upward again to turn on the optical flow mode, the aircraft status indicator light is green.

## One-Key Landing:

During flight, long-press the One-Key Landing button, and the aircraft will initiate a landing at its current position. While landing, the remote control can still be used to control the aircraft. Pushing the throttle up during the landing process will cancel the landing. Alternatively, pressing the One-Key Landing button again will cancel the one-key landing function.

## Expert Inverted Flight Mode:

Fly the aircraft to a height of 5 meters or more, first switch to the large rudder volume state, and then switch to manual flight mode, press the inverted flight button for two seconds to enter the one-key inverted flight mode, the aileron rocker to the left or right quickly hit the stick and quickly back to the center, the aircraft according to the stick command to automatically enter the 180-degree roll and hovering, **at this time the helicopter inverted flight state operation flight and fly as well as the same, the throttle rocker on the thrust vehicle climb, lift Throttle rocker push forward, the aircraft moves to the nose direction.**

Press the one-key inverted flight button again, the aileron rocker quickly hit the stick, the aircraft from inverted flight roll to forward flight state, and return to normal flight.

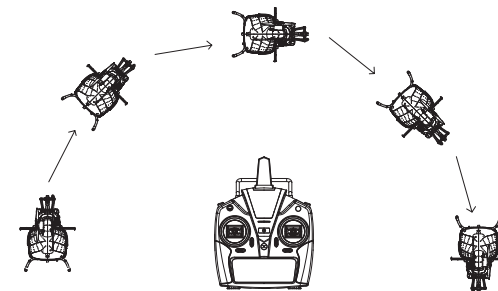

⚠ Note: The craft only opens up aileron rolls to the left or right, not forward and backward rolls

## Pitch Setting:

When users replace servos or other major components, it may alter the pitch setting. Correct pitch setting contributes to stable flight. Please follow the steps below for pitch setting.

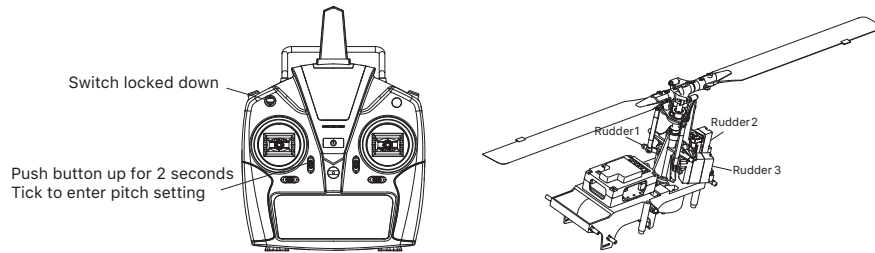

- 1 Power on the aircraft and bind it to the remote controller.
- 2 First, dial the throttle lock switch to the locked state, and then long press the pitch setting button to make two drops to enter the pitch setting.
- 3 Adjust the corresponding servo by the rocker until the aircraft cross disk is horizontal and the angle of the propeller is 0 degrees. Then short press the lock button. The remote controller unlocks by the drop sound to exit the pitch setting and save it. Press the lock button again.

 Note: Pitch setting should be done under the guidance of an experienced individual. Incorrect pitch setting can result in reduced flight performance.

## Common Troubleshooting:

| No. | Issue   | Solution  |
|-----|---|---|
| 1   | After powering on, the indicator light keeps flashing rapidly.                | The aircraft is in gyroscope self-checking state. Please place the aircraft on a stationary and flat surface.                                   |
| 2   | The aircraft tilts to one side and cannot hover after takeoff.                | Place the aircraft on a level tabletop or surface and recalibrate the gyroscope.  |
| 3   | The aircraft experiences severe shaking.                                      | Check for damaged rotor blades and replace them with new ones. Inspect the main shaft and cross-axis for any bending and replace them promptly. |
| 4   | The aircraft cannot be unlocked, and the indicator light flashes red rapidly. | The battery voltage is too low. Please fully charge the battery.  |
| 5   | Unstable flight in strong wind conditions.                                    | Fly in appropriate weather conditions. The aircraft is suitable for flying in wind conditions up to level 4.                                    |
| 6   | No response from the helicopter after power on, slow flashing light.          | Rebind the frequency. During rebinding the aircraft should be placed horizontally.  |
| 7   | Slow flashing green light in downward vision flight mode.                     | Ground environment may affect the performance of the downward vision system. Please test in a different environment.                            |
| 8   | No power-on sound when connecting power to the helicopter.                    | The speed controller may be faulty or the plug connection is poor. Replace the speed controller and inspect the plug for timely replacement.    |
| 9   | Continuous beeping from the remote control during flight.                     | The aircraft voltage is low, triggering a level 1 alarm. Replace the AAA batteries in the remote control.                                       |