

Specifications:

Power Supply:DC 12V 24V/ AC 110V-220V

Temperature Control Range:-55°C-120°C

Resolution Ratio: 0.1° C(-9.9-99.9); 1° C(other range)

Color of Displaying: red/blue

Measurement accuracy: $\pm 0.1^{\circ}$ C

Control accuracy: 0.1° C

Sensor: NTC10K Waterproof sensor

Output: Relay Contact Capacity 20A 12V / 10A 220V

Environmental requirements: -10-60° C , humidity 20%-85%RH

Dimension:79mm *43mm*26mm

Cutting Size:73mm*39mm

Sensor wire: 1 meter

Function description:

P0: refrigeration or heating mode

P1: return difference setting

P2: maximum temperature setting upper limit

P3: minimum temperature setting lower limit

P4: temperature correction

P5: delay start time (unit: minute)

Step to use:

- Press SET once and the display temperature flashes. Press +- to SET the required temperature (press +- to quickly rise and fall). Press SET to confirm and return, and the controller will automatically execute relay on and off as SET. The output of the thermostat is 10A relay, which can meet various high-power loads. The thermostat can be supplied by connecting the control circuit. At this time, the display screen shows the ambient temperature.

Indicator light, digital tube status description.

- Indicator light: flashing indicates the delay of starting refrigeration or heating, and constant flashing indicates that the relay has closed

- Digital tube: display LL to open the sensor, please connect the sensor according to the instructions; Show HH as out of measuring range temperature controller will force off relay;

Display - alarm for high temperature

Parameter function description

- Long press SET 5 seconds to enter the main menu setting, press +- toggle P0...P6, long press SET

or 10 seconds keyless action controller automatically confirm return.

P0: Refrigeration and heating modes

- Long press SET 5 seconds to display P0, press SET once to SET the working mode, press +/- to switch [H for heating mode] [C for refrigeration mode] to press SET once to return, long press SET or 10 seconds for keyless action controller to automatically confirm completion.

- In refrigeration mode: when the measured temperature is \geq the temperature setting point, the refrigeration relay pulls in and the refrigerator starts; When the temperature measurement value \leq temperature setting point - return difference, the refrigeration relay is disconnected and the refrigerator is shut down.

- In heating mode: when the measured temperature \leq temperature setting point, the heating relay pulls in and the heater starts; When the measured temperature is $>$ temperature setting point + return error, the heating relay will be disconnected and the heater will be closed.

P1: Error setting

- Long press SET for 5 seconds to display P0, press +/- to switch to P1, press SET once to SET the difference back, press +/- to SET the difference back to 0.1-15, press SET once to return after completion, long press SET or 10 seconds keyless action controller to automatically confirm completion.

- In refrigeration mode: when the temperature measured value $>$ set value, the relay will pull in and the refrigerator will start; When the temperature measured value \leq set value - return difference value, the relay is disconnected and the refrigerator is shut down.

- To 30 °C, such as environment value of 25 °C, return difference set to 2 °C, the electric relay closed refrigerating unit after the start, when the refrigeration to 23 °C, relay disconnect refrigerating unit shut down, at this time due to the refrigerating unit has been disconnected temperatures began to rebound, when back up to the value of 25 °C, relay closed refrigerating unit to start again, so repeated cycle control temperature is not higher than 25 °C.

- In heating mode: when the measured temperature is \leq set value, the relay pulls in and the heater starts; When the temperature measured value \geq set value + return difference value, the relay is disconnected and the heater is off.

- For 10 °C, such as environment value of 25 °C, return difference set to 2 °C, the electric relay closed after the heater starts, when heated to 27 °C, relay disconnect heater closed, at this time due to the heater has disconnect temperature starts to drop, to the present value of 25 °C, relay closed heater to start again, so repeated cycle control temperature is not lower than 25 °C.

P2: Set upper limit for maximum temperature

- In order to avoid the danger of setting the temperature too high due to the misoperation of others, the thermostat has the function of setting the upper limit, which limits the setting range of the maximum temperature setting point controlled by the thermostat.

- Long press SET for 5 seconds to display P0, press +/- to switch to P2, press SET once to SET the upper limit, press +/- to SET the highest temperature that can be SET, the maximum value is 110, press SET once to return, long press SET or the keyless action controller for 10 seconds to automatically confirm completion.

- For example: If the setting point is set to 60, the highest setting point can only be set to 60 °C. If the setting point is higher than the setting point, the range of temperature needs to be expanded, and the upper setting value needs to be adjusted first.

P3: Lower limit of the lowest temperature is set

- In order to avoid ice blocking caused by other people's misoperation, the temperature controller has the function of minimum setting upper and lower limits, which limits the setting range of the minimum temperature setting point controlled by the temperature controller.
- Long press SET to display P0 for 5 seconds, press +/- to switch to P3, press SET once to SET the lowest limit, press +/- to SET the lowest temperature that can be SET, the lowest value is -50, press SET once to return after completion, long press SET or 10 seconds keyless action controller to automatically confirm completion.
- For example: the setting point of temperature 2 can only be set as low as 2°C. If the setting point of temperature is lower than 2°C and the range of temperature is expanded, the setting value of lower limit needs to be adjusted first.

P4: Temperature correction

- This function can be used to correct the deviation between the measured temperature and the standard temperature or due to special needs of the user's hardware. The corrected temperature = the temperature before the correction + the correction value has an effective range of -7.0~7.0.
- Long press SET for 5 seconds to display P0, press +/- to switch to P4, press SET once for correction, press +/- to SET correction value, press SET once for return after completion, long press SET or 10 seconds for automatic confirmation of completion of keyless action controller.
- For example, the normal display is 25 degrees; Display 25 degrees when the temperature is adjusted to 0; Display 26.5 degrees when the temperature is adjusted to 1.5; Display 23.5 when temperature correction is -1.5.

P5: Delayed start time (unit: minutes)

- Turn on the delay function to protect the service life of the equipment when delay is required for the refrigerating unit or heater.
 - Long press SET for 5 seconds to display P0, press +/- to switch to P5, press SET once to SET delay start up time in minutes, press +/- to SET 0-10 minutes, press SET once to return, long press SET or 10 seconds for keyless action controller to automatically confirm completion
 - In refrigeration mode: when the first power is switched on, if the current temperature > set value, the refrigeration unit will not start immediately, and it will start after the set delay time.
 - In heating mode: power on for the first time, if the current temperature < set value, the heater will not start heating immediately, and it will start after running the set delay time.
 - When the shutdown time between two adjacent starts of the refrigerator or heater is greater than the set value of delayed start time, the refrigerator will start immediately
 - When the stop interval between two adjacent starts of the refrigerator or heater is less than the set value of delayed start time, the device can only be started after the set delayed start time of the refrigerator has been run a gain. Delay time is calculated from the moment of stop.
- ,such as refrigeration condition set delay for 5 minutes, after startup refrigerating unit startup latency, 5 minutes to open the refrigerator when reach the required temperature refrigerator to stop, start the time right now, the next time a refrigerator start timing immediately when finished work, end of the timing for timing to work unfinished, delay in the LED light is flashing-
- When the delay start is set to 0, the delay function is turned off.

How to save Settings

- To save the set data, set P7 to ON in the case of continuous power after setting the temperature, so that the last setting will be retained no matter how the power is cut off.
- factory data reset

•Due to some human reason, the internal Settings of the thermostat are chaotic, and it takes a long time to set one item at a time. At this time, this function can be used to restore factory Settings. The specific method is: in the shutdown state, press + and - buttons at the same time, and then start up, a 11 the above parameters will be restored to factory Settings.

Wiring



12V Connecting mode

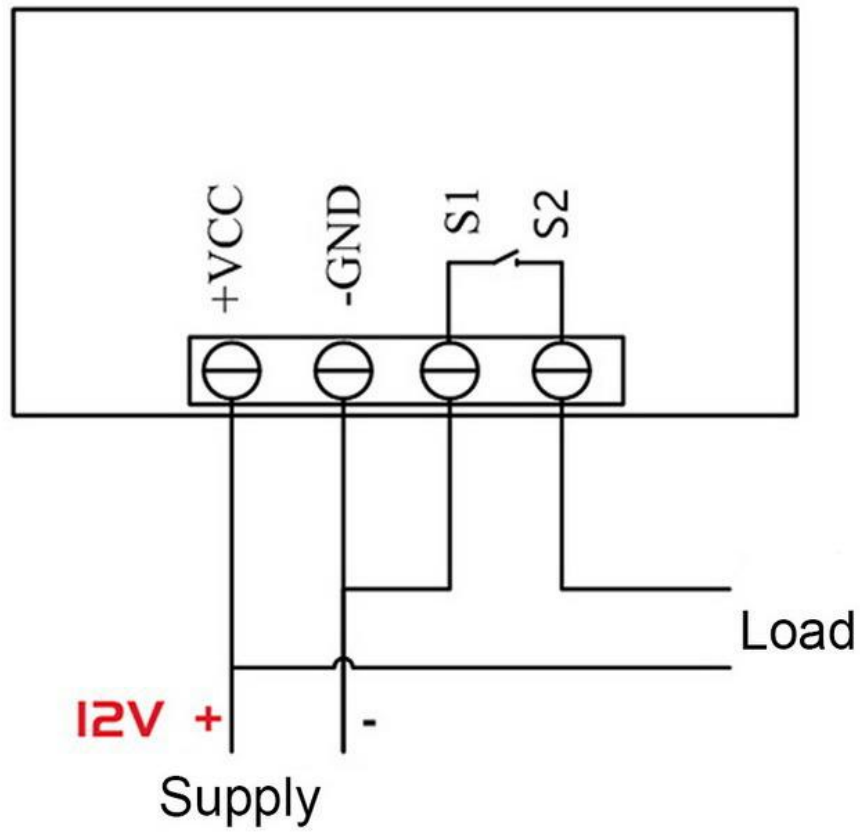

110V-220V Connecting mode

